

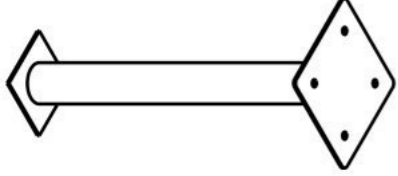

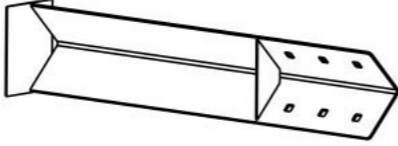

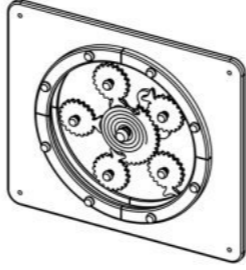

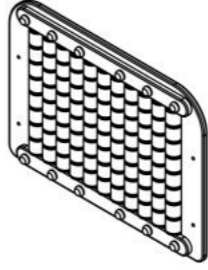
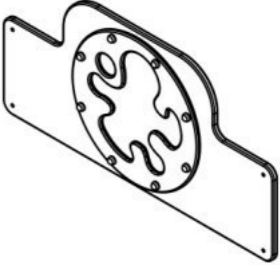
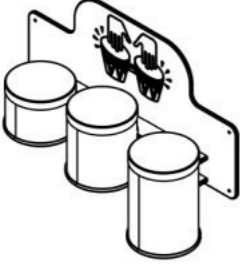
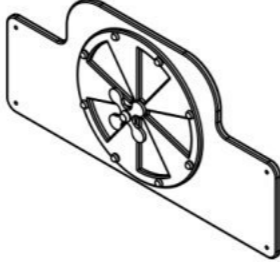
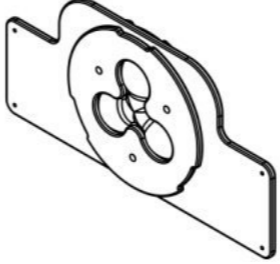
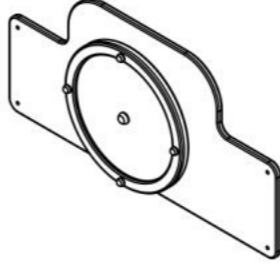
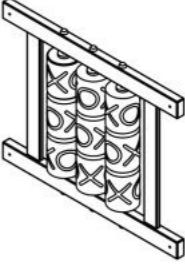
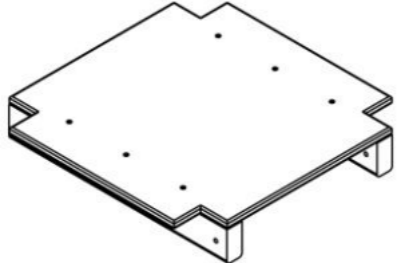

Инструкция по сборке  
4439.0000.0000

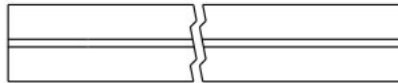
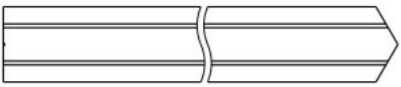
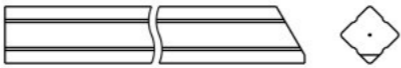
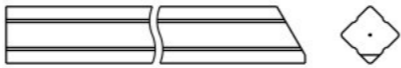
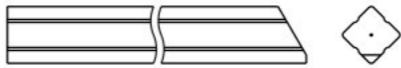
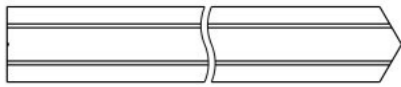
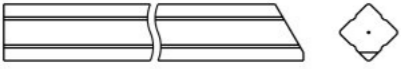

Таблица 1 — Составные части оборудования

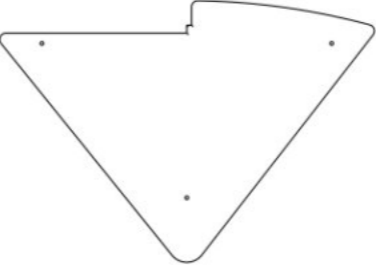
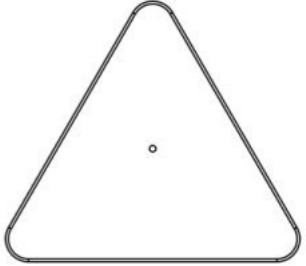
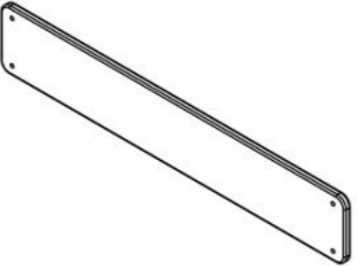
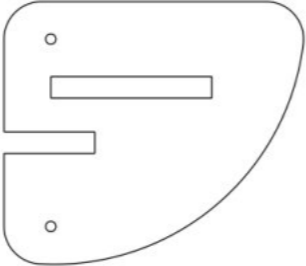
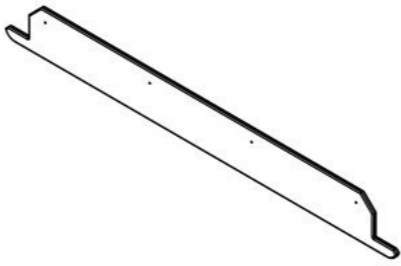
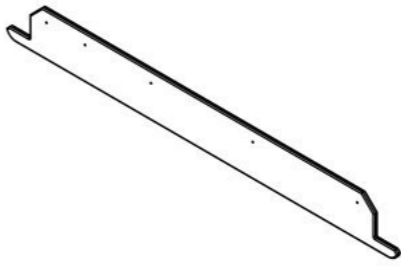
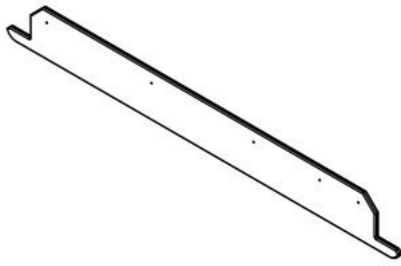
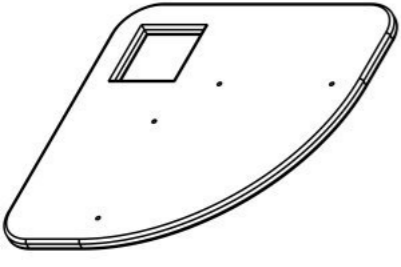
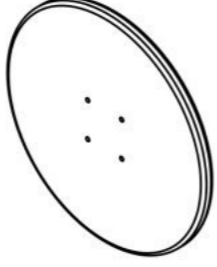
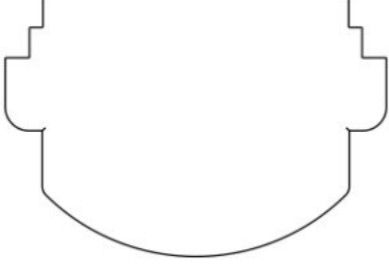
 <p>0000.0036.0000 — 4 шт</p>	 <p>0000.0318.0000 — 12 шт</p>	 <p>0000.7337.0000 — 1 шт</p>	 <p>0000.7339.0000 — 1 шт</p>	 <p>0000.7340.0000 — 1 шт</p>
 <p>0000.7343.0000 — 1 шт</p>	 <p>0000.7348.0000 — 1 шт</p>	 <p>0000.7349.0000 — 1 шт</p>	 <p>0000.7350.0000 — 1 шт</p>	 <p>0000.7407.0000 — 1 шт</p>
 <p>0000.8241.0000 — 1 шт</p>	 <p>0000.S135.0000 — 5 шт</p>	 <p>0000.S150.0000 — 2 шт</p>	 <p>4439.S001.0000 — 1 шт</p>	 <p>0000.0000.S099 — 2 шт</p>

 <p>0000.0000.S132 — 1 шт</p>	 <p>0000.0000.S134 — 1 шт</p>	 <p>4439.0000.S002 — 1 шт</p>	 <p>4439.0000.S003 — 1 шт</p>	 <p>4439.0000.S004 — 1 шт</p>
 <p>4439.0000.S005 — 1 шт</p>	 <p>0000.0000.1666 — 1 шт</p>	 <p>0000.0000.1674 — 4 шт</p>	 <p>0000.0000.2264 — 2 шт</p>	 <p>0000.0000.2265 — 2 шт</p>
 <p>0000.0000.2266 — 1 шт</p>	 <p>0000.0000.6255 — 2 шт</p>	 <p>0000.0000.6262 — 2 шт</p>	 <p>0000.0000.6263 — 1 шт</p>	 <p>0000.0000.6264 — 1 шт</p>
 <p>0000.0000.6265 — 1 шт</p>	 <p>0000.0000.6266 — 2 шт</p>	 <p>0000.0000.6254 — 1 шт</p>	 <p>SO08.080 (Винт самонар., полусфер., с пресс-шайбой, TORX, 8×80) — 92 шт</p>	 <p>SO08.120 (Винт самонар., полусфер., с пресс-шайбой, TORX, 8×120) — 8 шт</p>



SS05.050.D7982 (Винт самонар.,  
потай., 5×50, DIN 7982) — 26 шт



SS06.070.D7982 (Винт самонар.,  
потай., 6×70, DIN 7982) — 16 шт

Инструкция по сборке описывает порядок сборки оборудования для одного вида установки (варианта монтажа). В таблице 2 указано какая опора применяется на оборудовании в зависимости от варианта монтажа.

Таблица 2 — Таблица применяемости опор оборудования

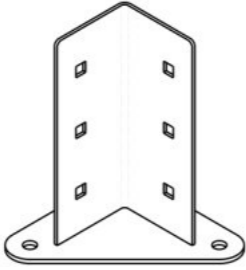
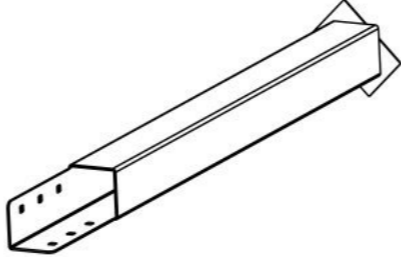
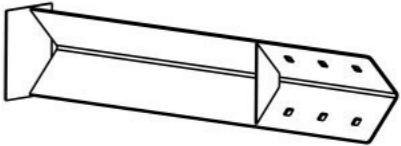
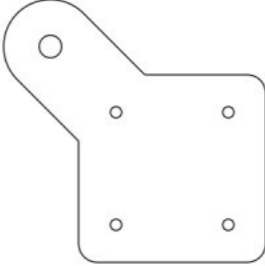
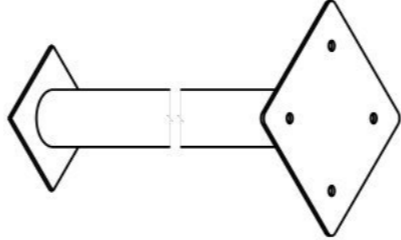
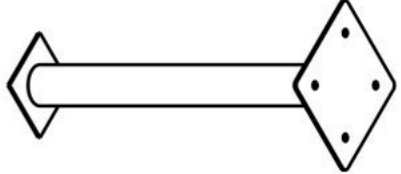
Анкер. СУПП <sup>1</sup>	Бетон. НУПП <sup>2</sup>	Бетон. СУПП <sup>3</sup>
 <p data-bbox="498 646 703 678">0000.0319.0000</p>	 <p data-bbox="1418 646 1623 678">0000.0320.0000</p>	 <p data-bbox="2338 646 2543 678">0000.0318.0000</p>
 <p data-bbox="498 1094 703 1125">0000.0000.0556</p>	 <p data-bbox="1418 1094 1623 1125">0000.0263.0000</p>	 <p data-bbox="2338 1094 2543 1125">0000.0036.0000</p>

<sup>1</sup> — Монтаж с использованием анкерных опор и синтетического ударопоглощающего покрытия площадки

<sup>2</sup> — Монтаж с использованием бетонизируемых опор и насыпного ударопоглощающего покрытия площадки

<sup>3</sup> — Монтаж с использованием бетонизируемых опор и синтетического ударопоглощающего покрытия площадки



Рисунок 1



Рисунок 2

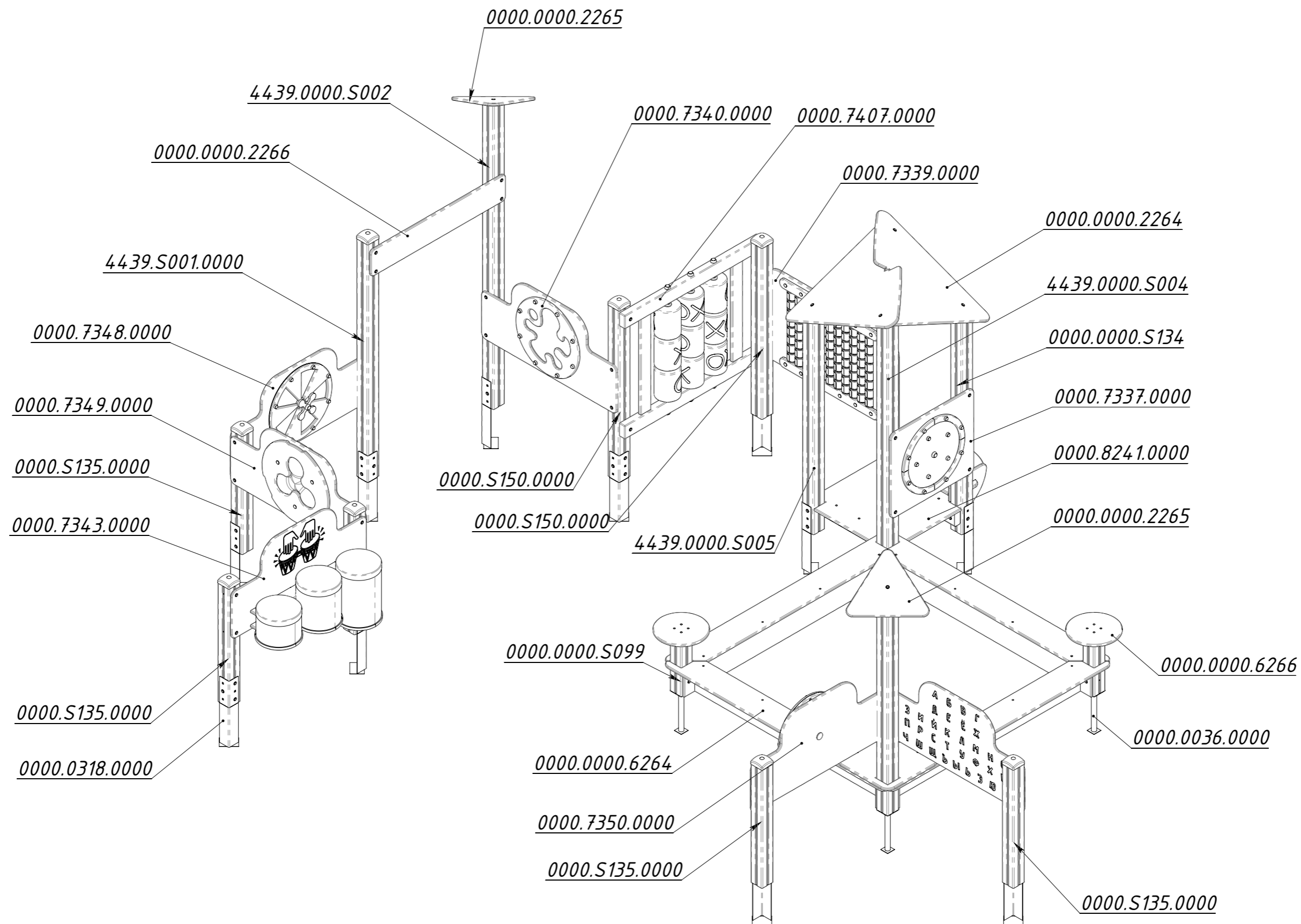

Рисунок 3



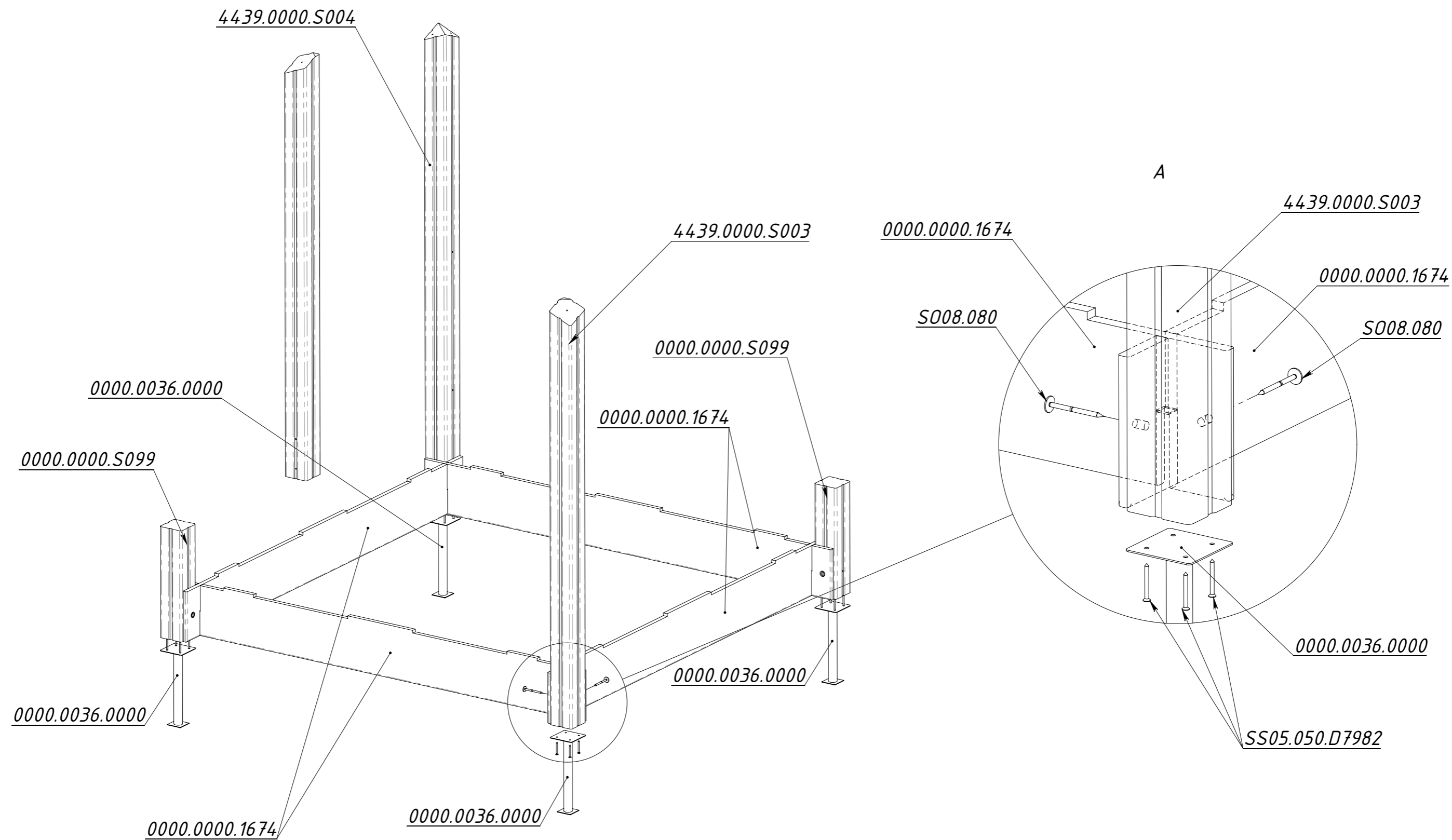

Рисунок 4

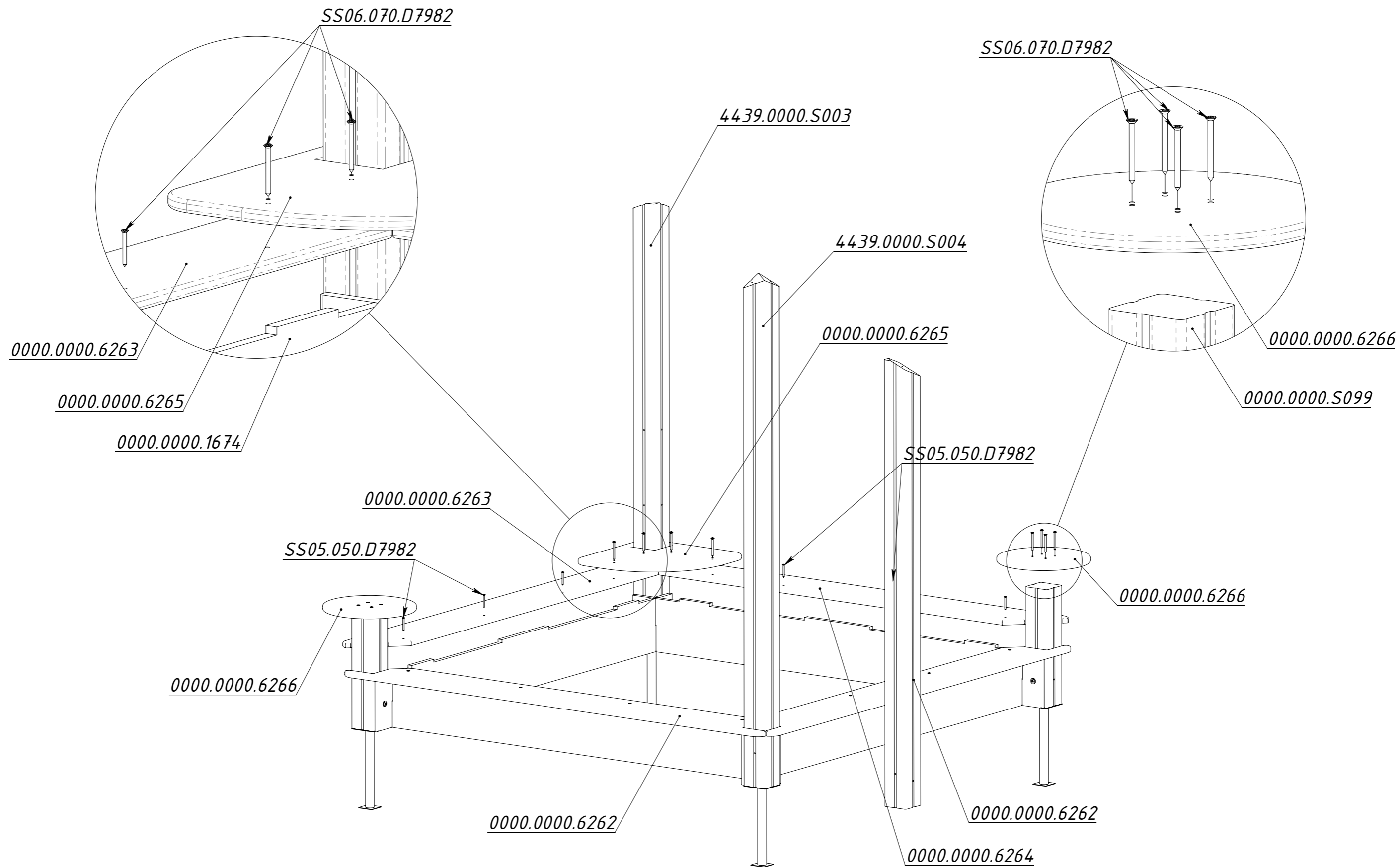

Рисунок 5

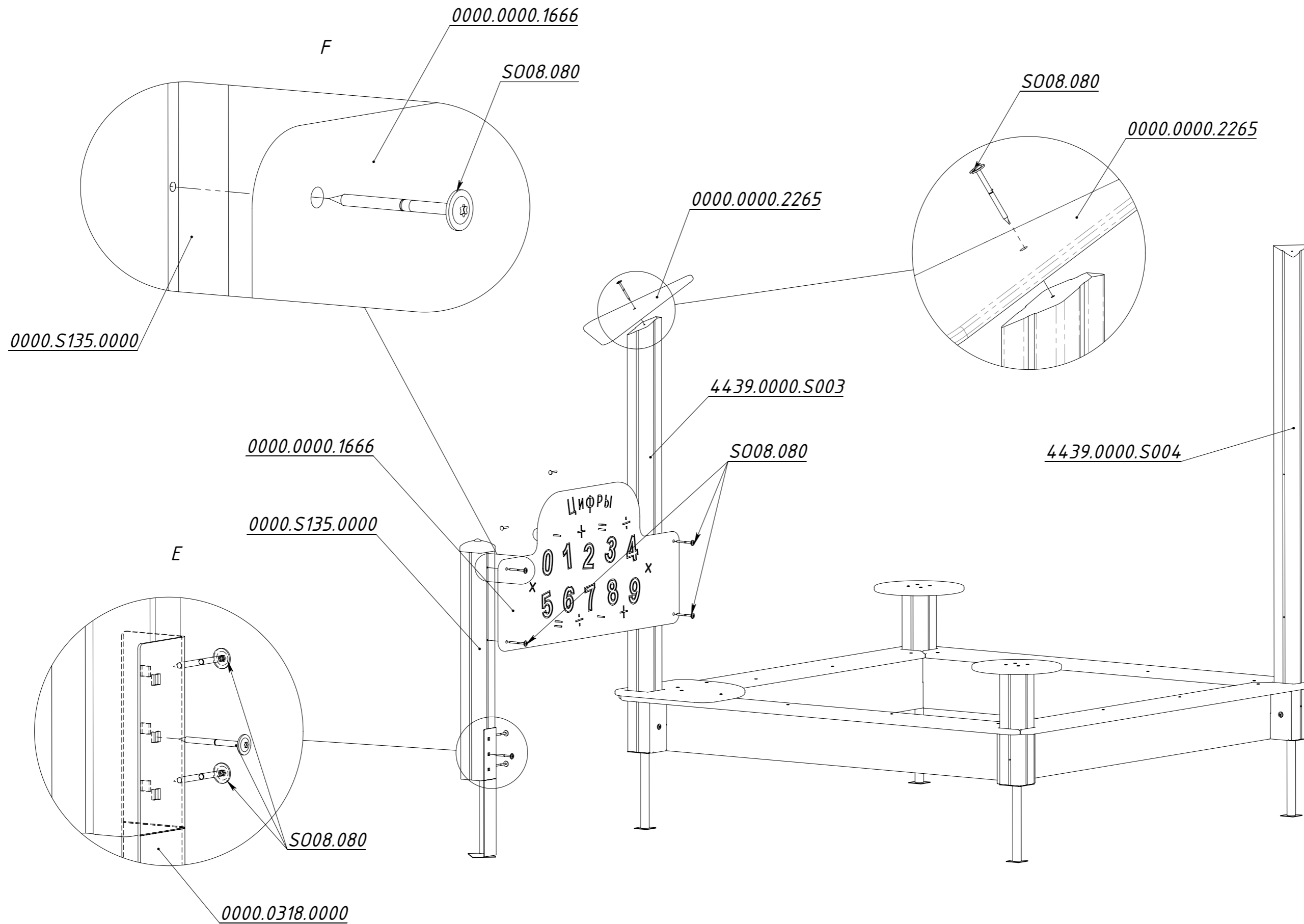

Рисунок 6

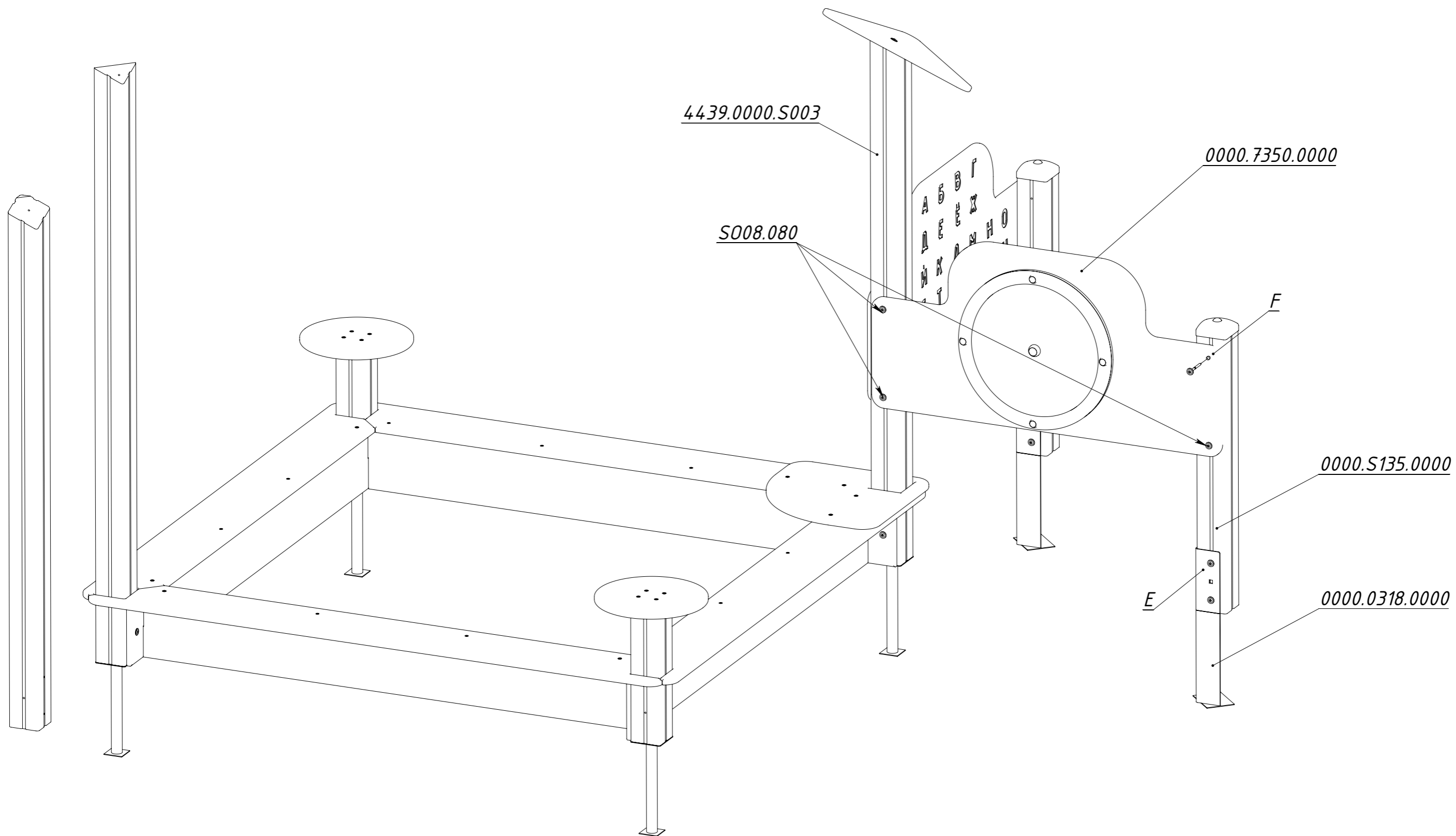

Рисунок 7

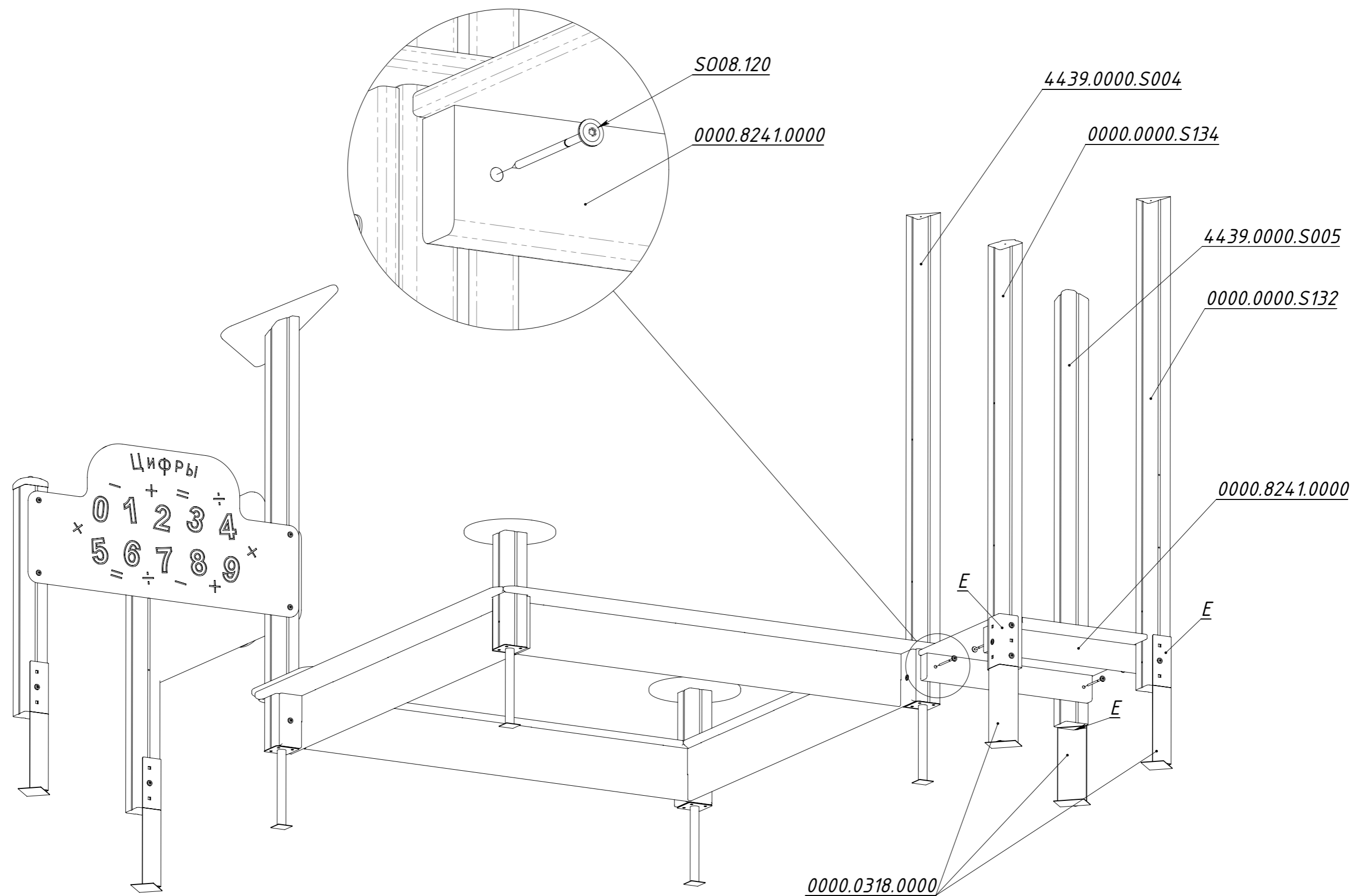

Рисунок 8

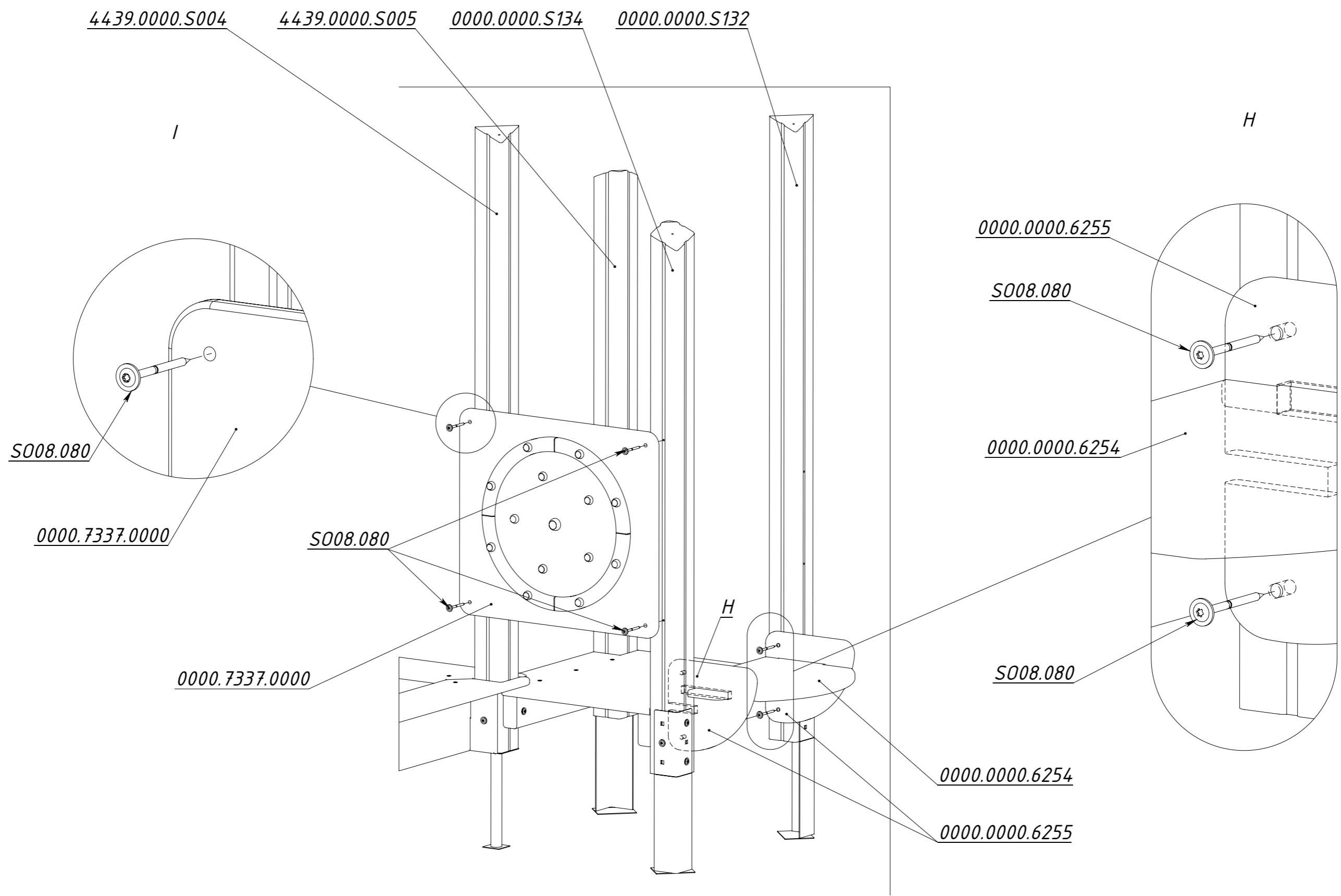

Рисунок 9

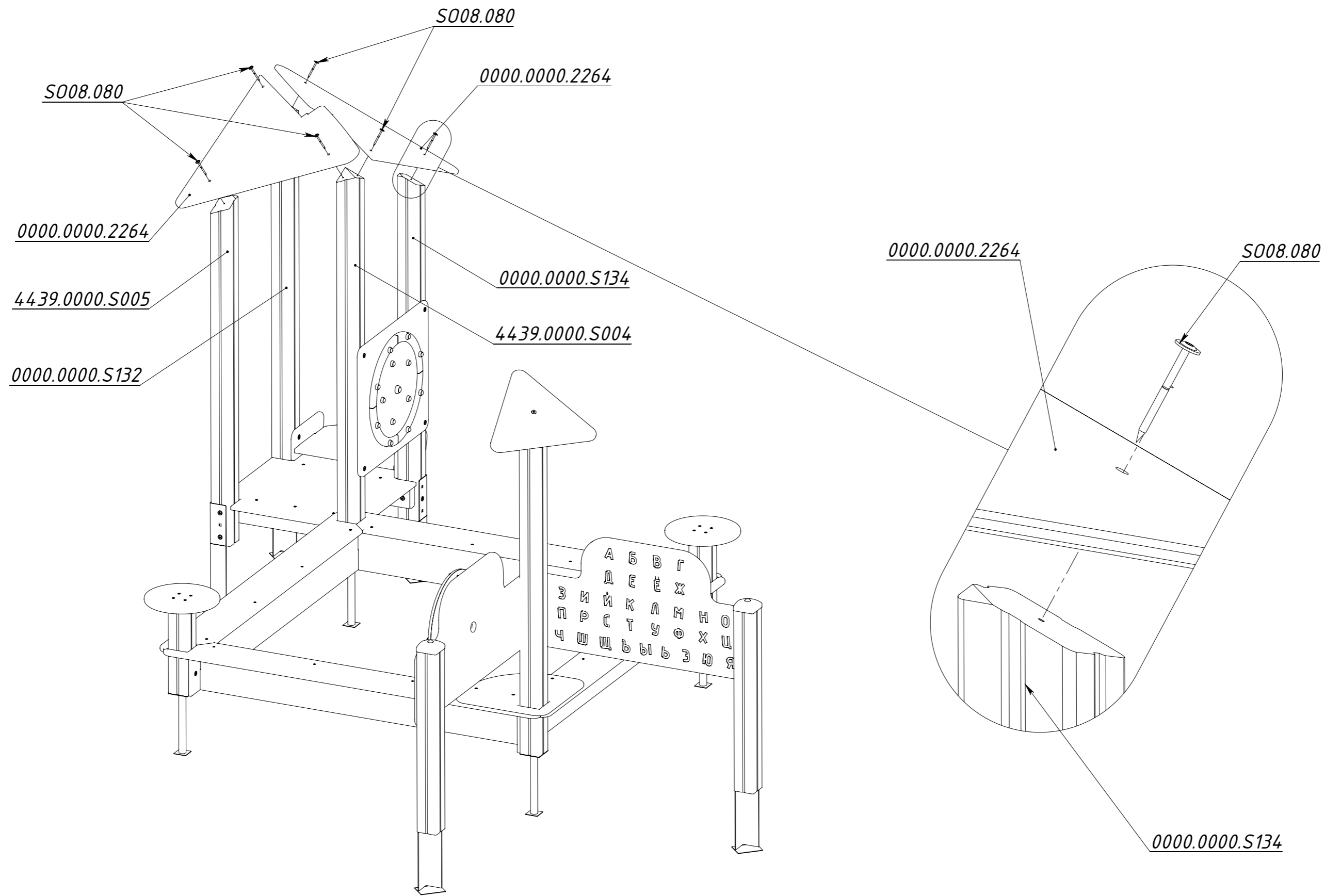

Рисунок 10

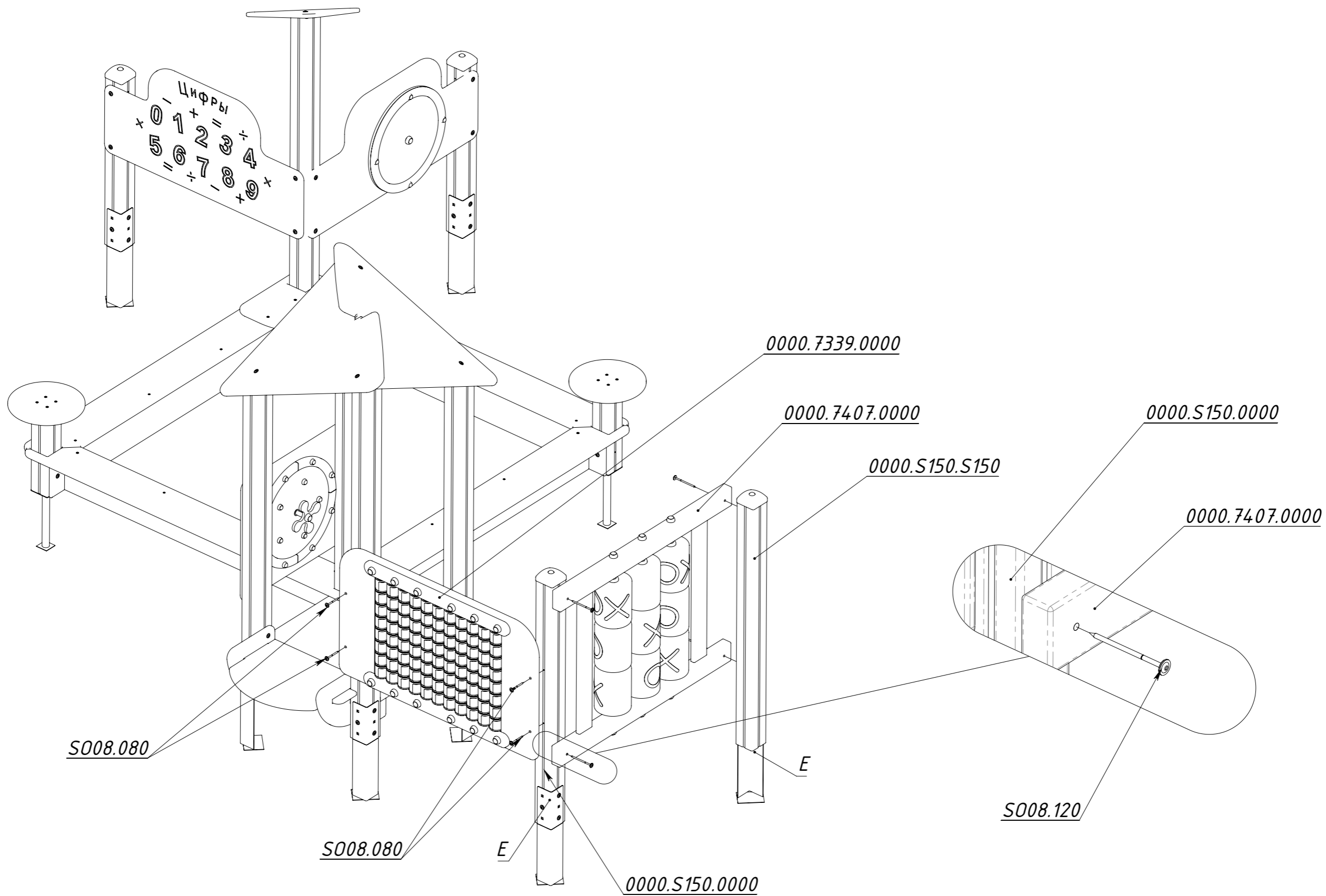
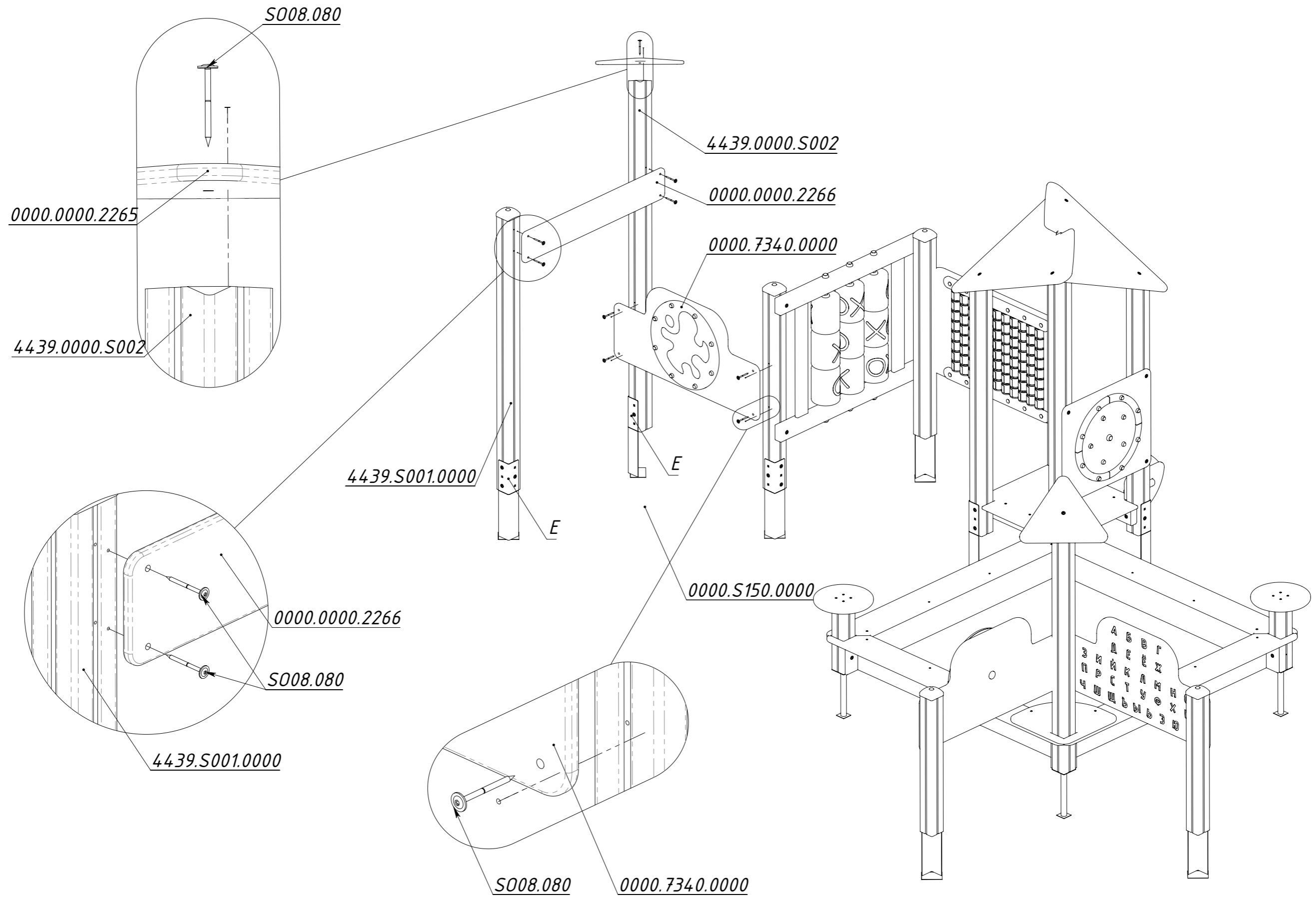
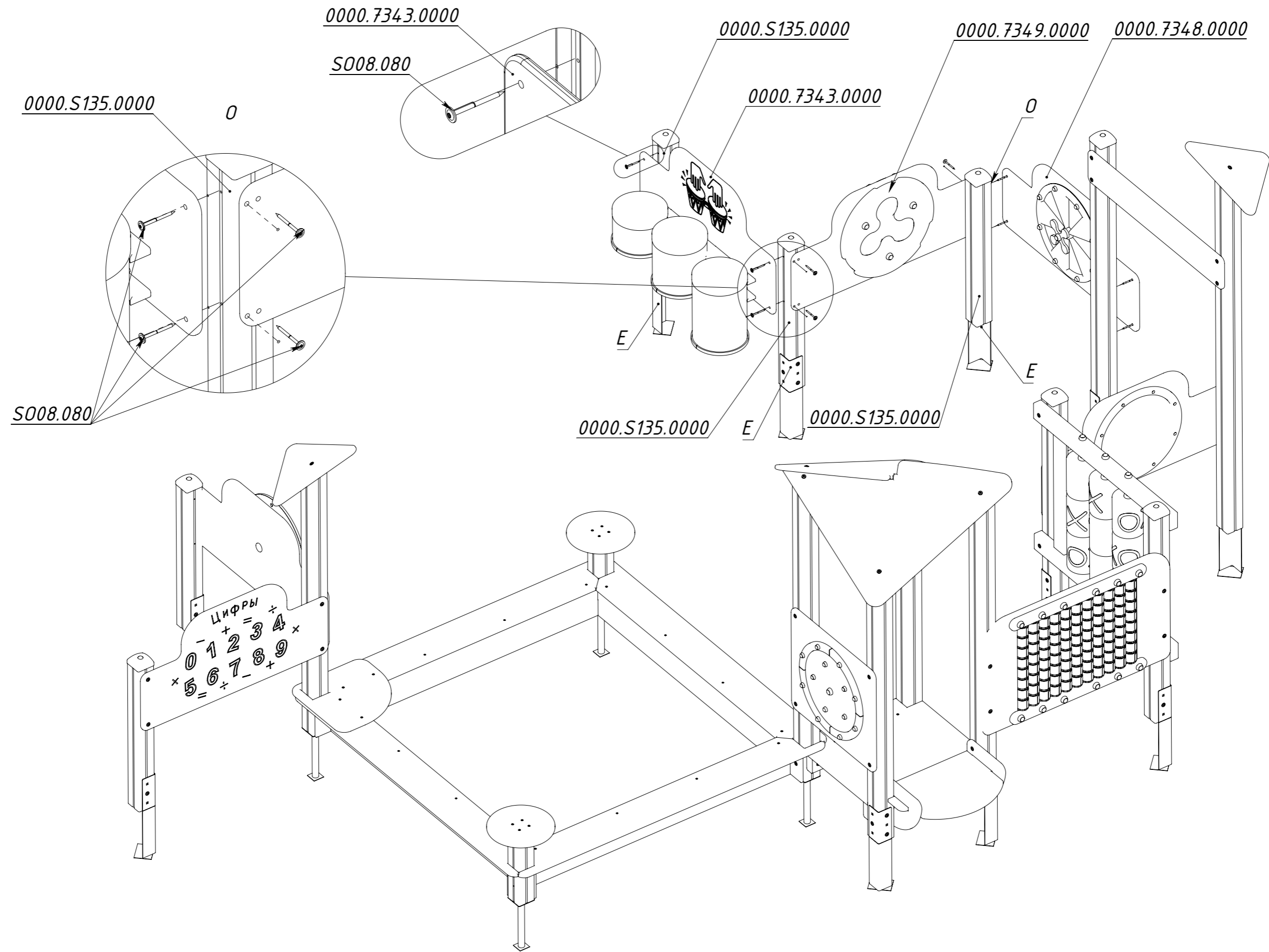

Рисунок 11