

**Инструкция по сборке**  
**E4002.0000.0000**











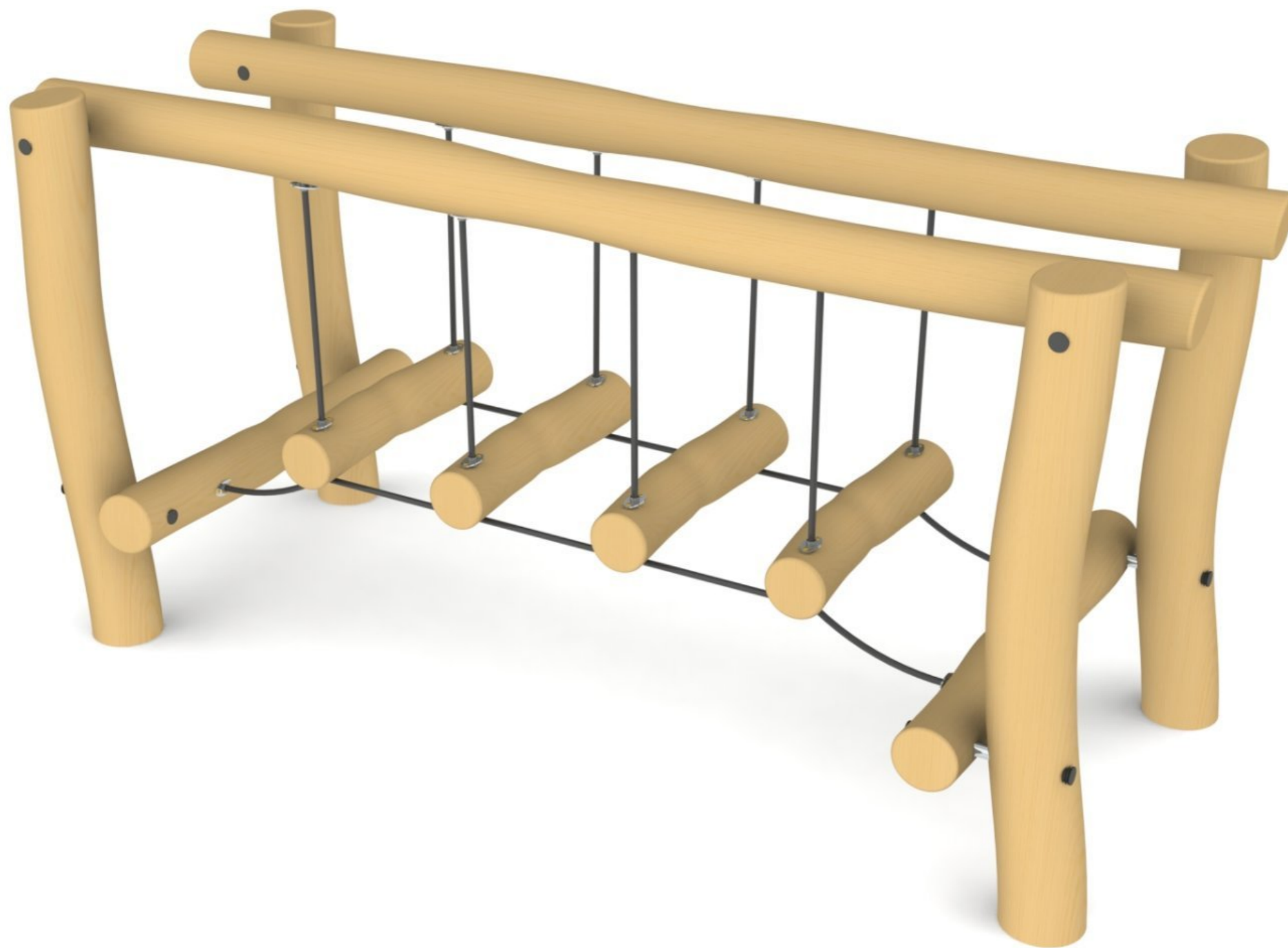
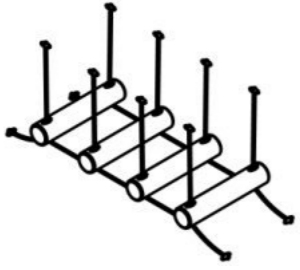



Таблица 1 — Составные части оборудования

 <p>E4002.0001.0000 — 1 шт</p>	 <p>E4002.0000.B001 — 1 шт</p>	 <p>E4002.0000.B002 — 1 шт</p>	 <p>E4002.0000.B003 — 1 шт</p>	 <p>E4002.0000.B004 — 1 шт</p>
 <p>E4002.0000.S005 — 1 шт</p>	 <p>E4002.0000.S006 — 1 шт</p>	 <p>E4002.0000.S007 — 1 шт</p>	 <p>E4002.0000.S008 — 1 шт</p>	 <p>0000.0000.0569 — 16 шт</p>
 <p>0000.0000.0568 — 8 шт</p>	 <p>0000.0000.0584 — 8 шт</p>	 <p>STP.0104 (Заглушка круглая, пластик., Ø40 мм) — 16 шт</p>	 <p>NT12.D985 (Гайка с пластиковой вставкой, M12, DIN 985) — 16 шт</p>	 <p>SH12.100.D571 (Винт самонар., с шестигр. головкой, 12×100, DIN 571) — 12 шт</p>

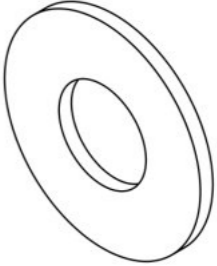
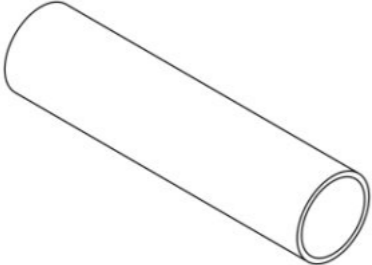

SO06.070 (Винт самонар., полусфер., с  
пресс-шайбой, TORX, 6×70) — 24 шт



WP12.A2.D9021 (Шайба увеличенная,  
нерж., M12, DIN 9021) — 16 шт



Рисунок 1

Схема 1.  
Соединение "бревно-бревно" через шпильку.

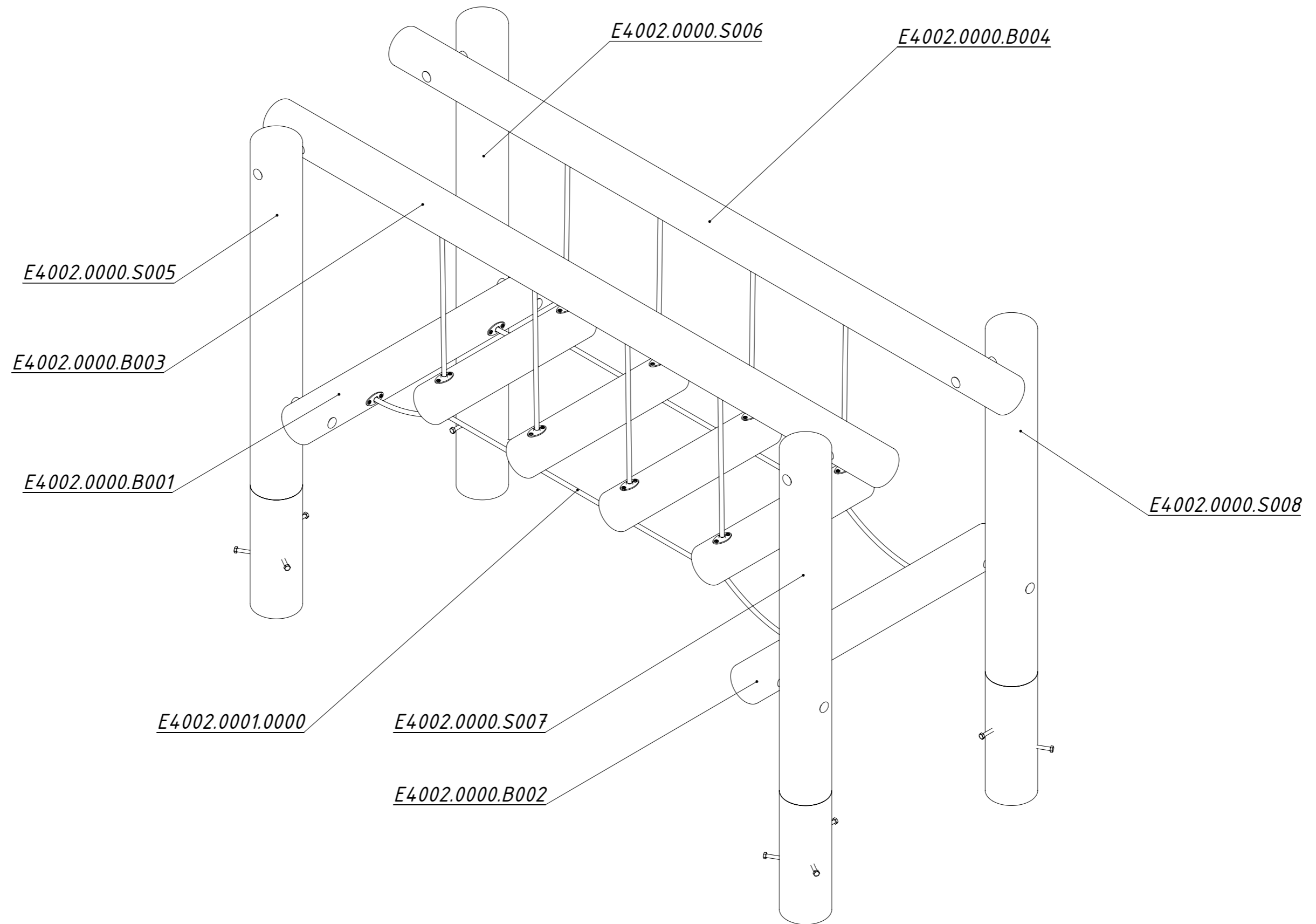

Рисунок 2

Схема 2.

Вариант 1.  
Крепление саморезов SH12  
на стойки без металлических опор.

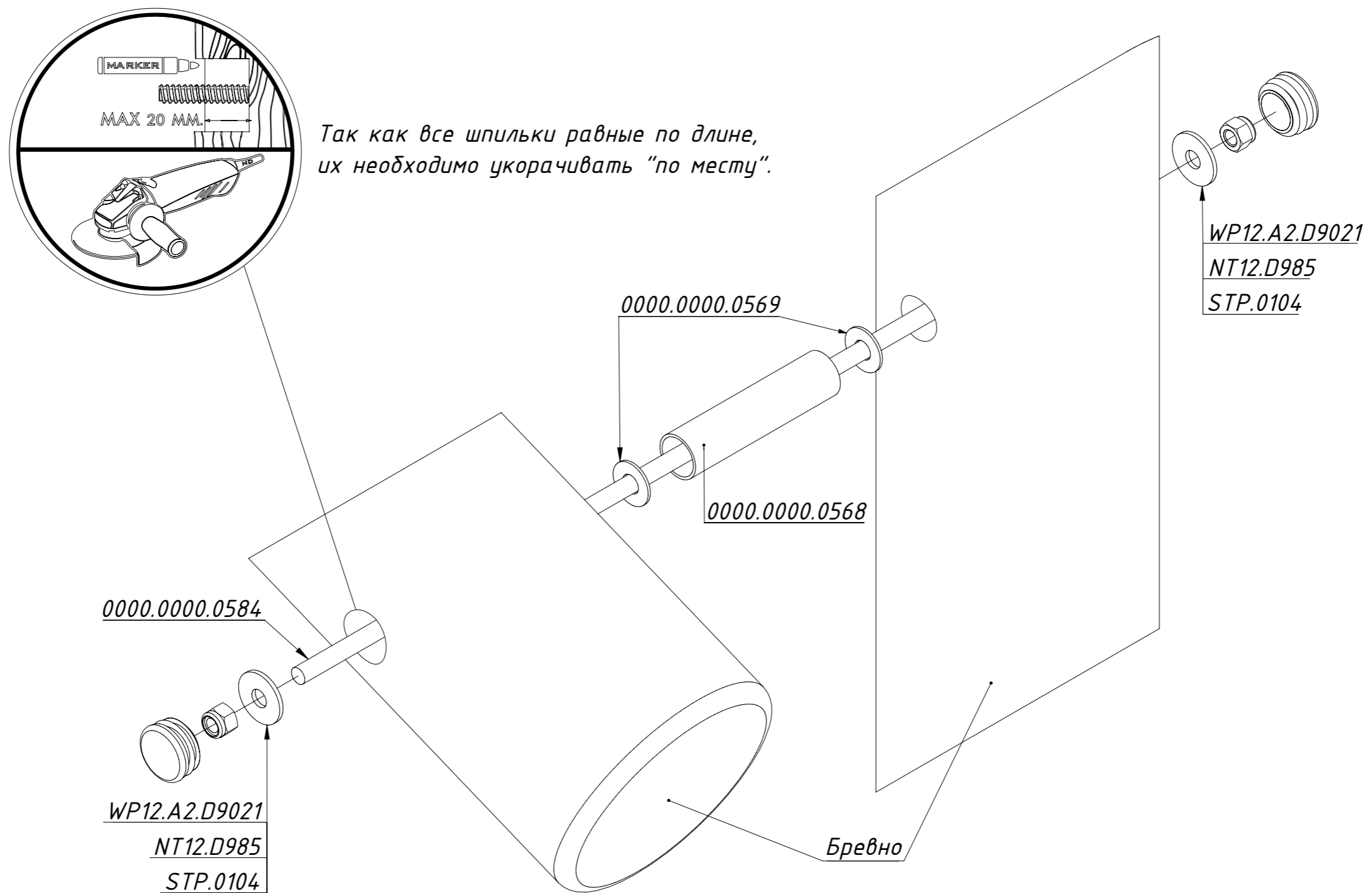
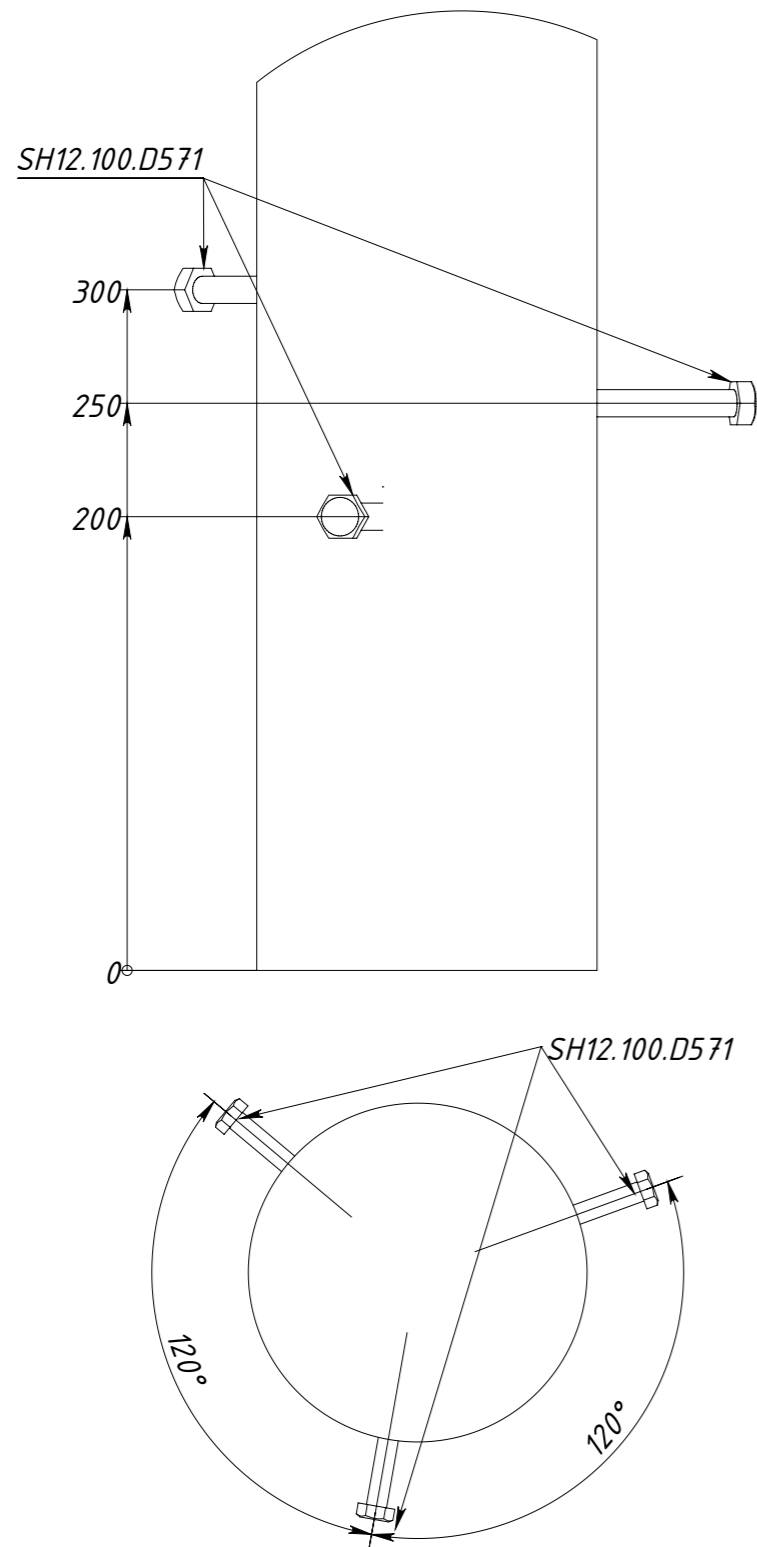

Вариант 2.

Крепление металлических опор к стойкам.



Рисунок 3



Рисунок 4

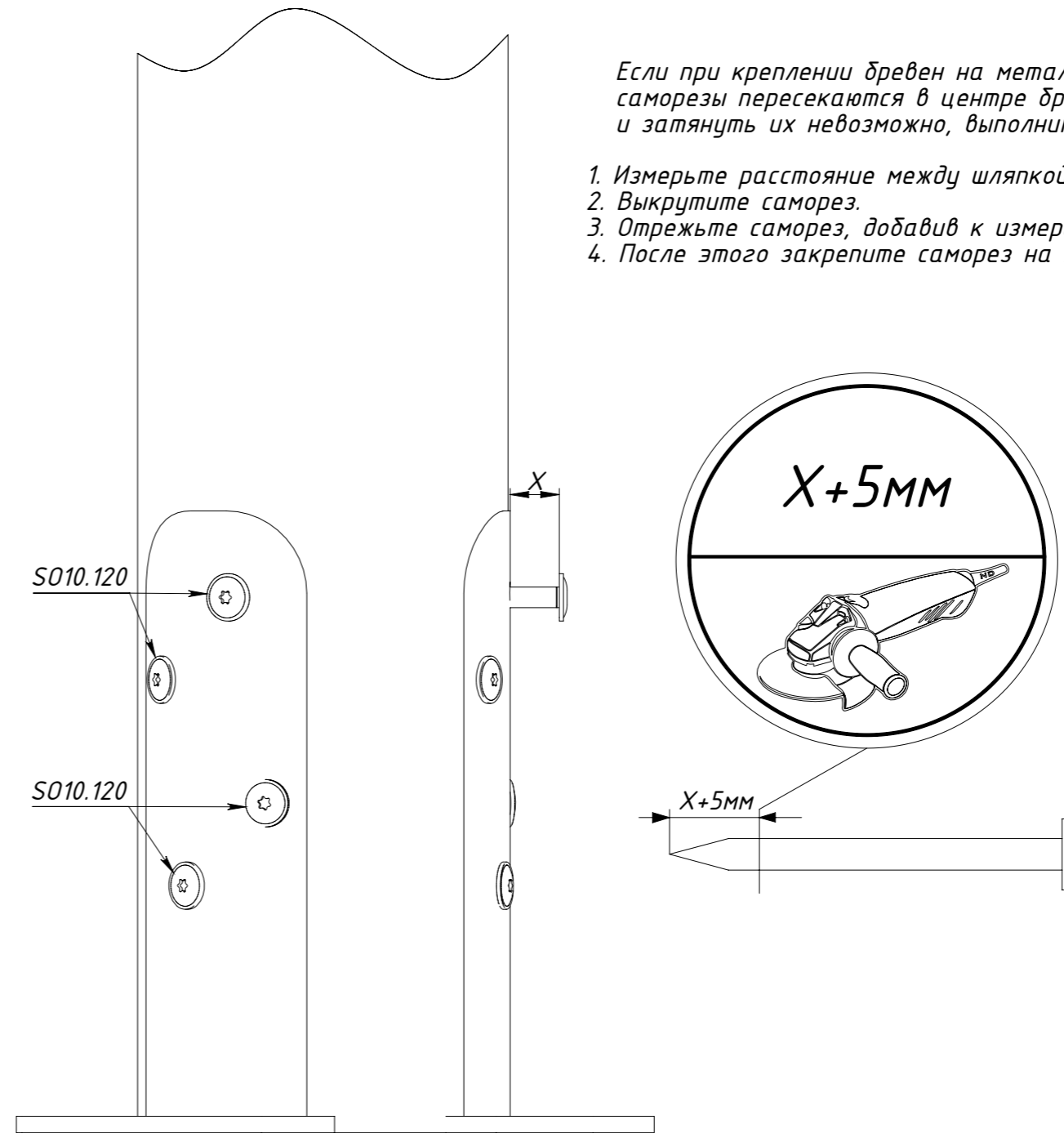
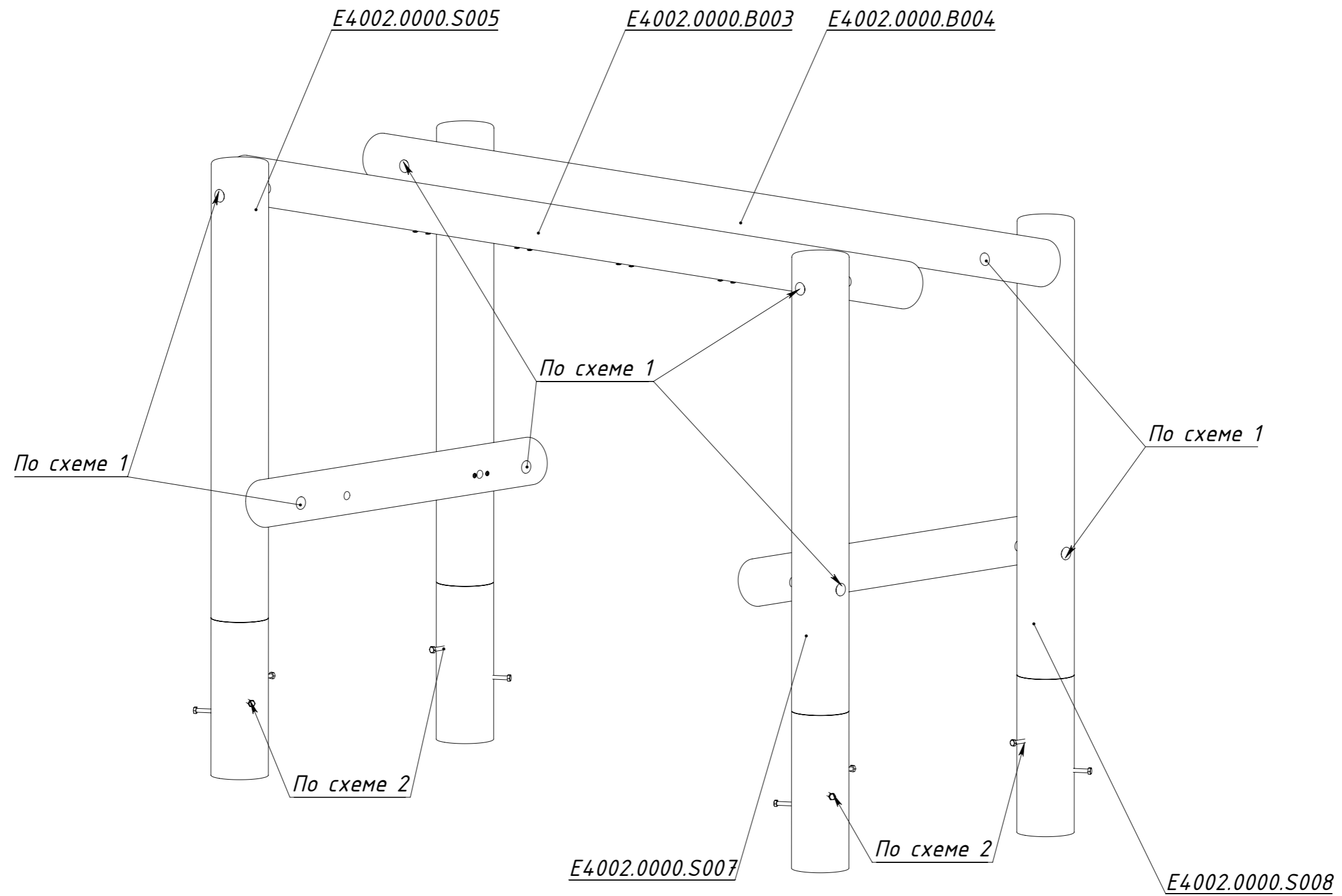
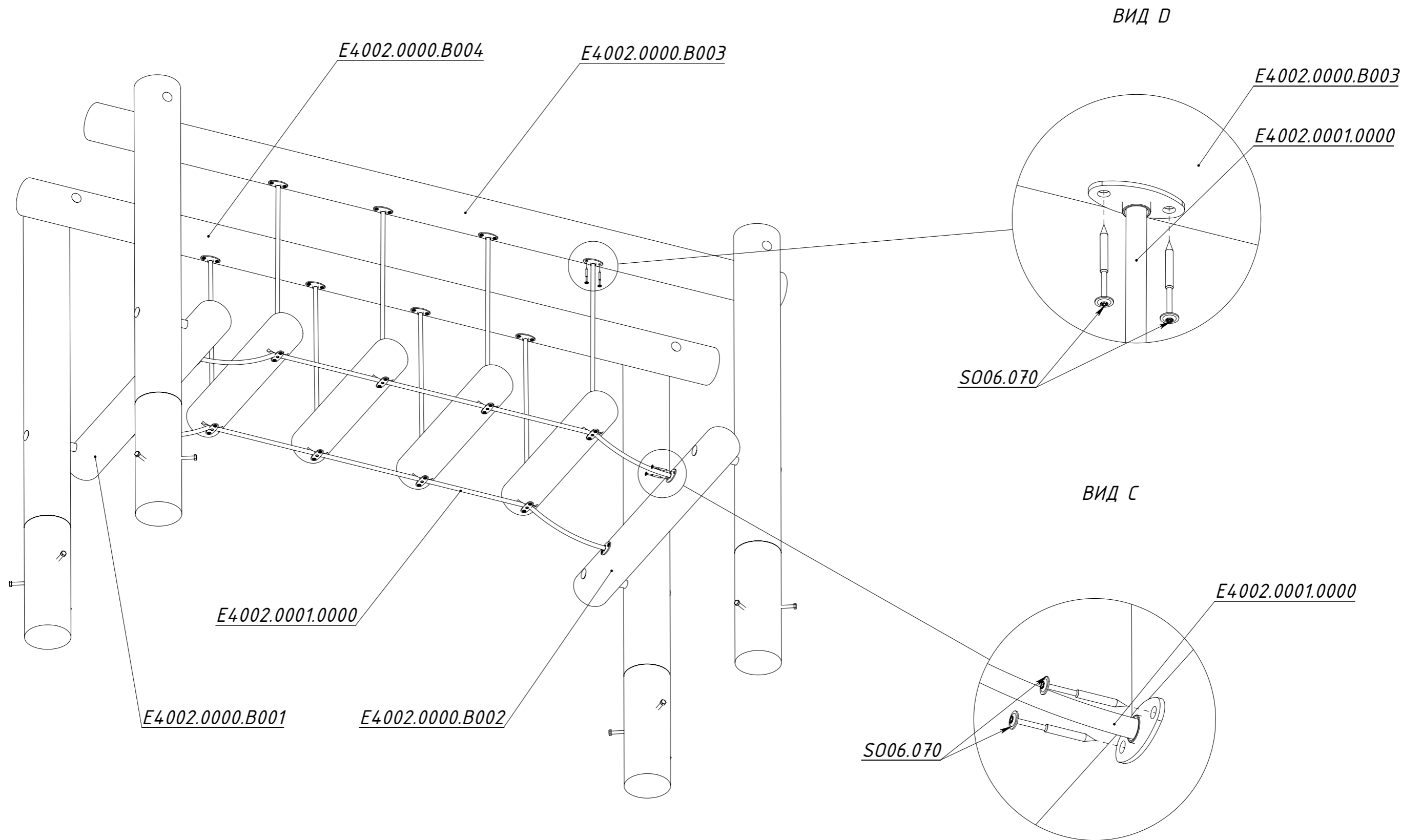

Рисунок 5