

Инструкция по сборке
E2009.0000.0000











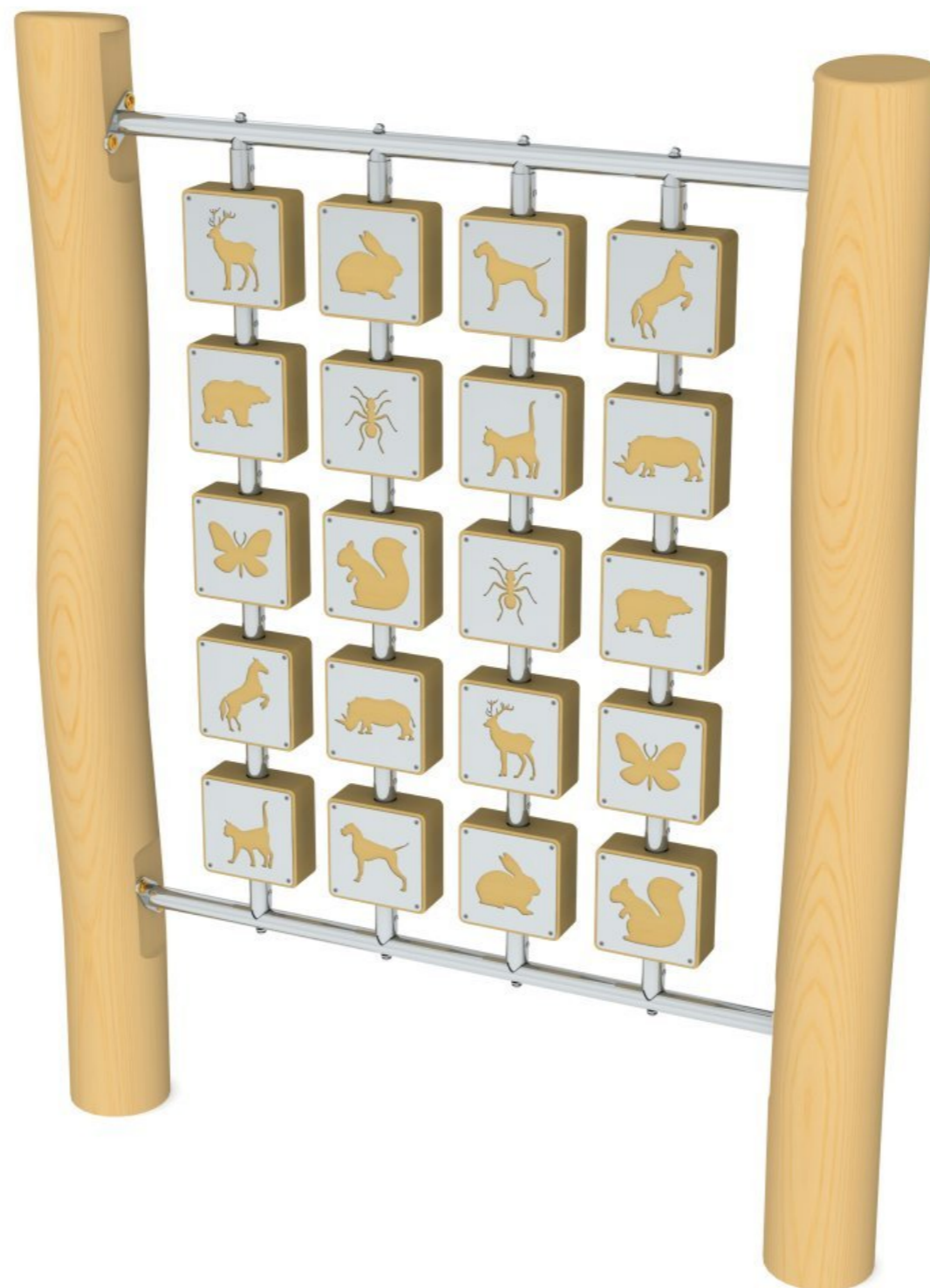



Таблица 1 — Составные части оборудования

 <p>E2009.0011.0000 — 1 шт</p>	 <p>E2009.0012.0000 — 1 шт</p>	 <p>E2009.0013.0000 — 1 шт</p>	 <p>E2009.0014.0000 — 1 шт</p>	 <p>E2009.0017.0000 — 2 шт</p>
 <p>E2009.0000.S001 — 1 шт</p>	 <p>E2009.0000.S002 — 1 шт</p>	 <p>BO08.030.A2.D7380 (Болт полусфер., с внутр. шестигр., нерж., M8×30, DIN 7380) — 8 шт</p>	 <p>SH12.100.D571 (Винт самонар., с шестигр. головкой, 12×100, DIN 571) — 6 шт</p>	 <p>SO08.080 (Винт самонар., полусфер., с пресс-шайбой, TORX, 8×80) — 8 шт</p>
 <p>WP08.A2.D125 (Шайба плоская, нерж., M8, DIN 125) — 8 шт</p>	 <p>WS08.A2.D127 (Шайба гроверная, нерж., M8, DIN 127) — 8 шт</p>			



Рисунок 1

Крепление саморезов SH12
на стойки без металлических опор.

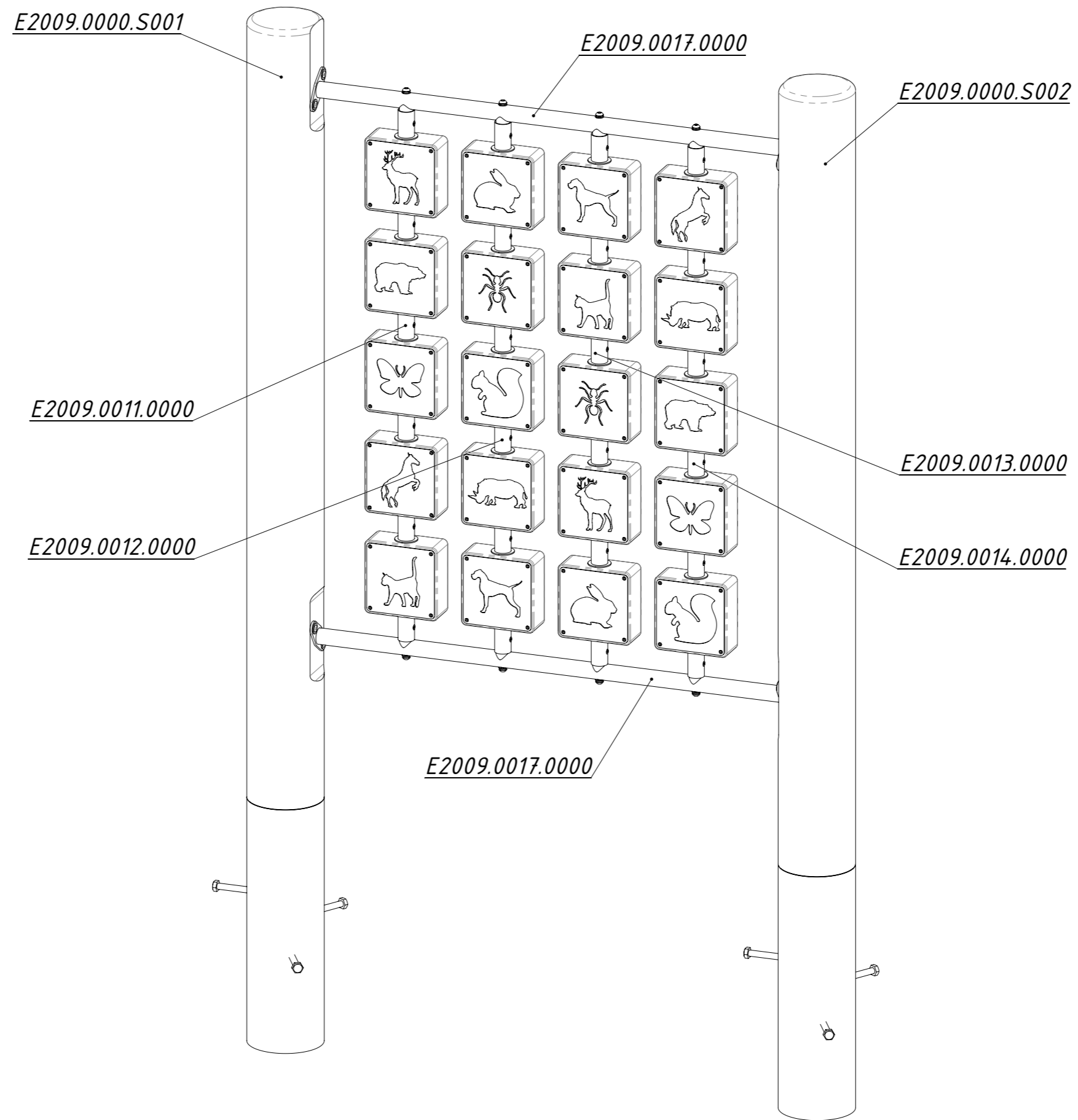

Схема 1.

Крепление металлических опор к стойкам.



Рисунок 2

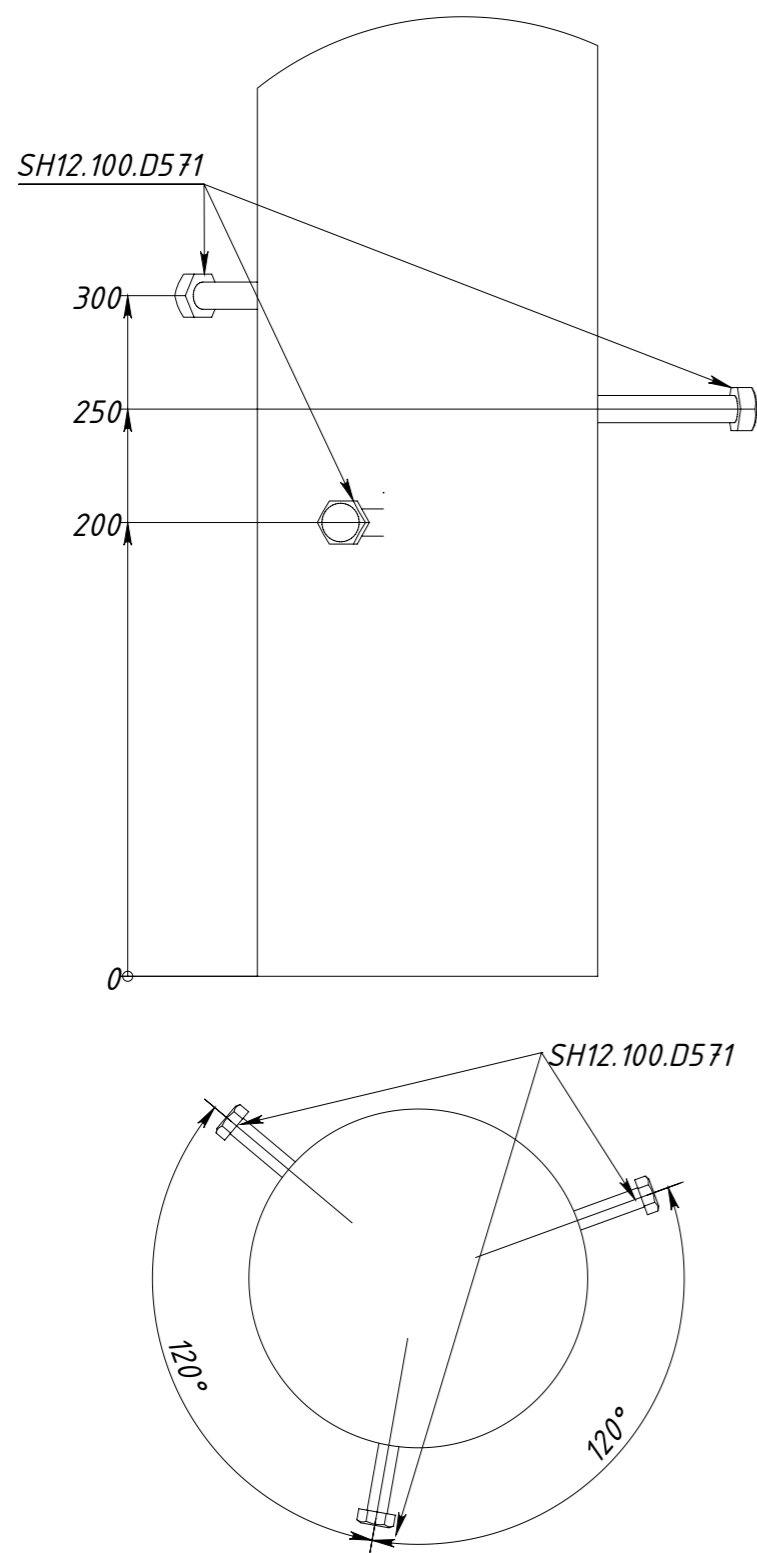

Рисунок 3

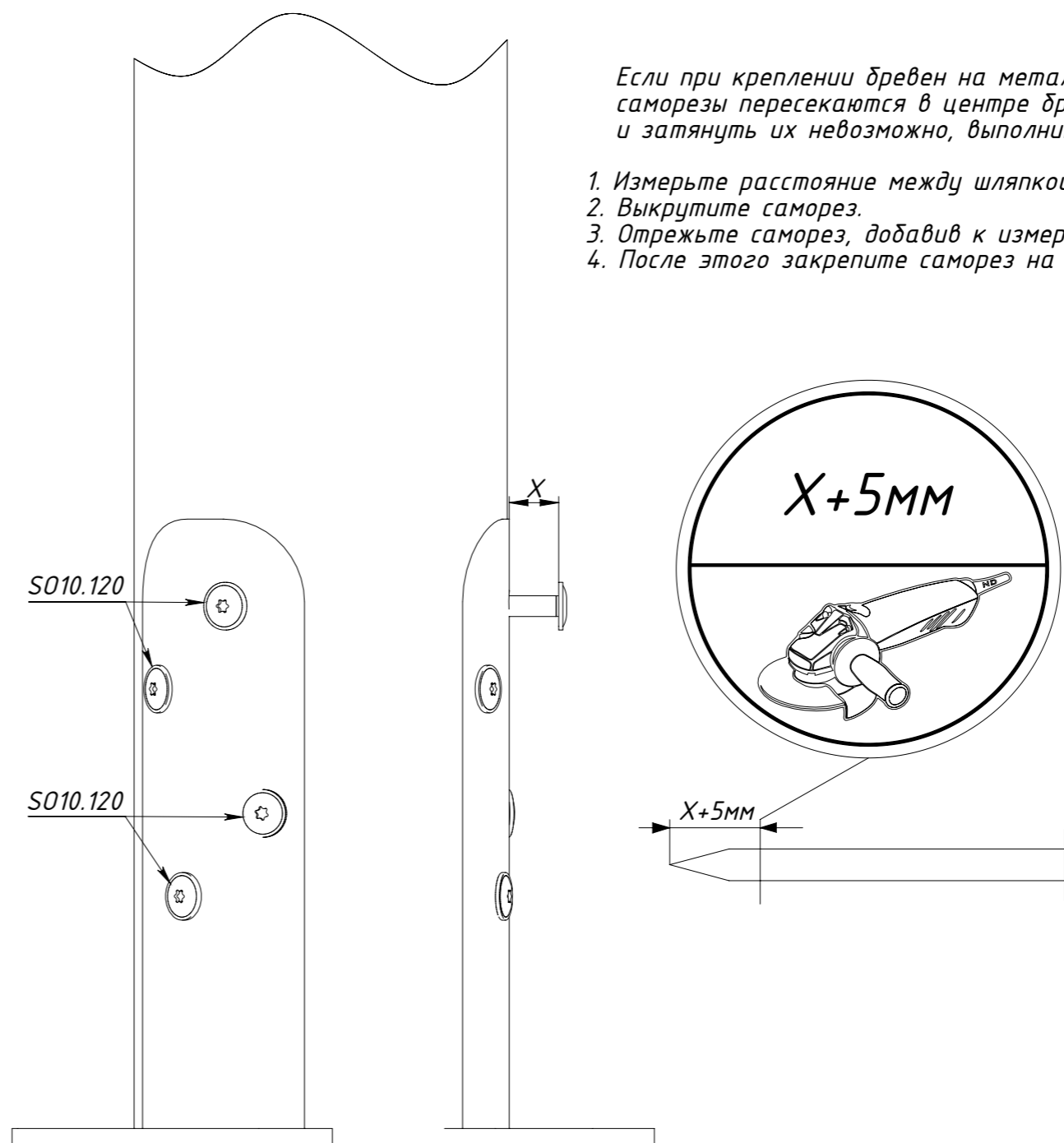
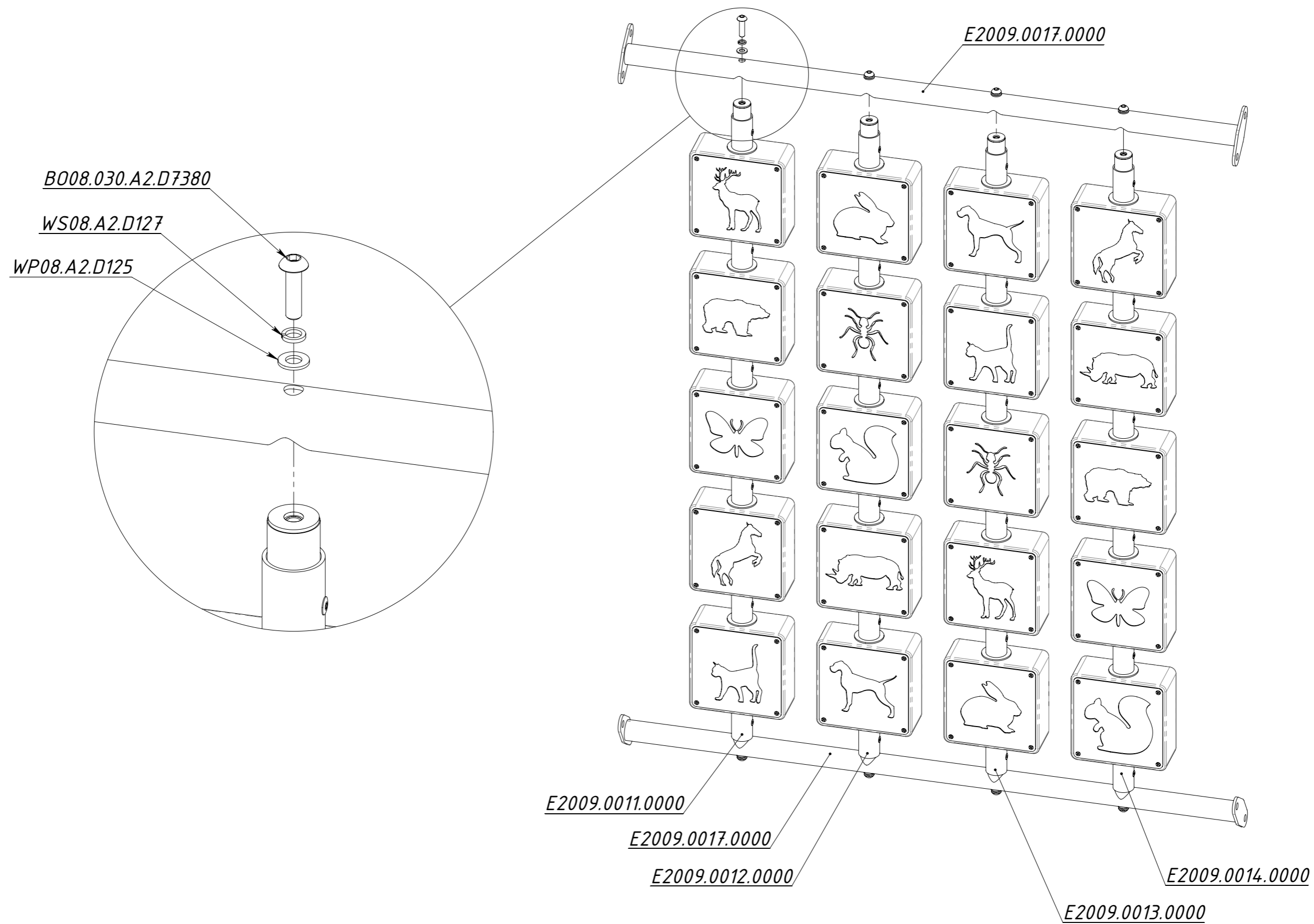
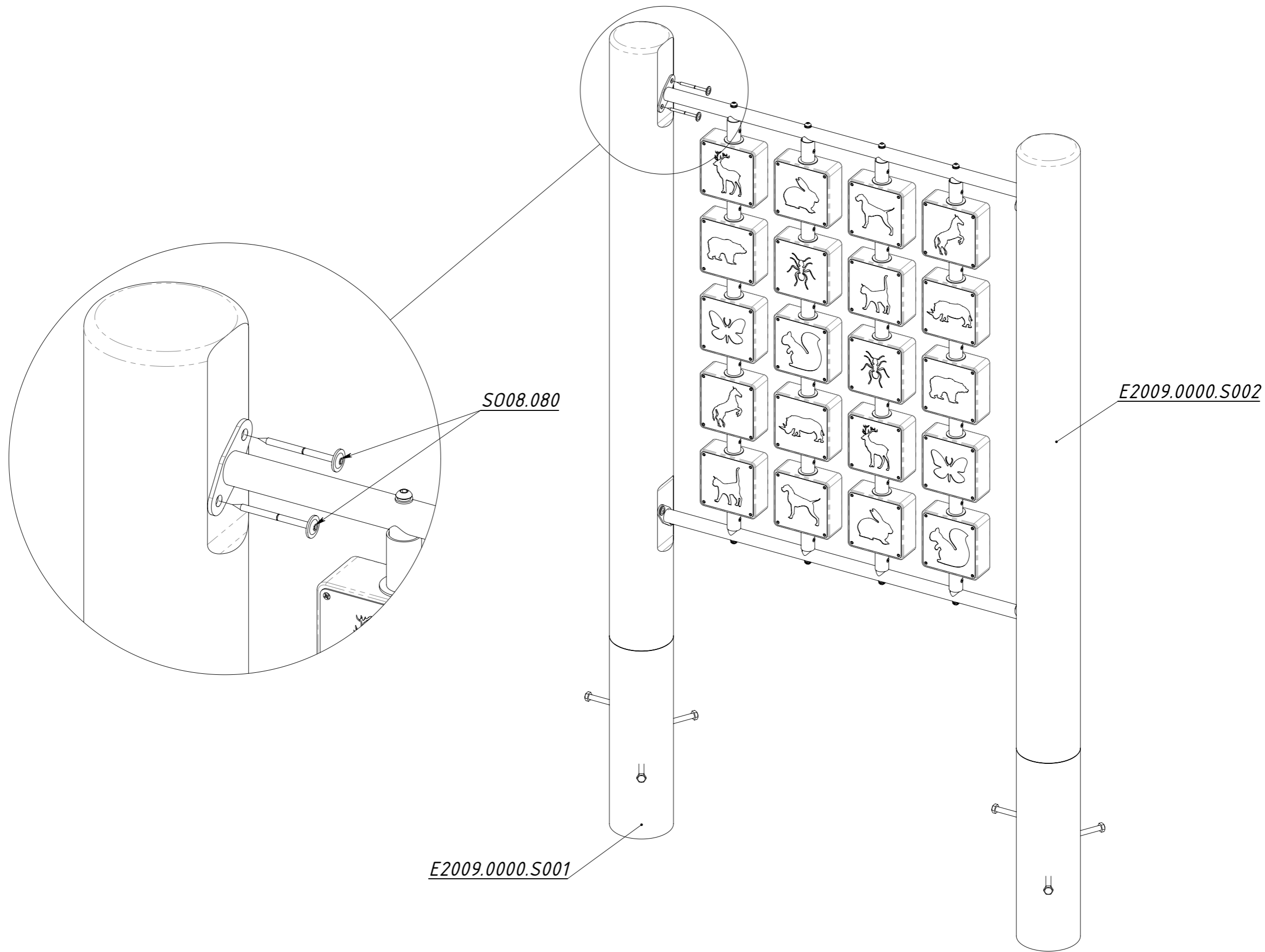

Рисунок 4