

Инструкция по сборке
7825.0000.0000



Таблица 1 — Составные части оборудования

 <p>0000.0100.0000 — 4 шт</p>	 <p>7825.0000.B003 — 2 шт</p>	 <p>7825.0000.B004 — 1 шт</p>	 <p>BF10.170.D603 (Болт меб., с квадр. подголовником, M10×170, DIN 603) — 2 шт</p>	 <p>ND10.D1587 (Гайка колпачковая, M10, DIN 1587) — 2 шт</p>
 <p>SO08.080 (Винт самонар., полусфер., с пресс-шайбой, TORX, 8×80) — 6 шт</p>	 <p>WP10.D9021 (Шайба увеличенная, M10, DIN 9021) — 2 шт</p>	 <p>WS10.D127 (Шайба гроверная, M10, DIN 127) — 2 шт</p>		



Рисунок 1

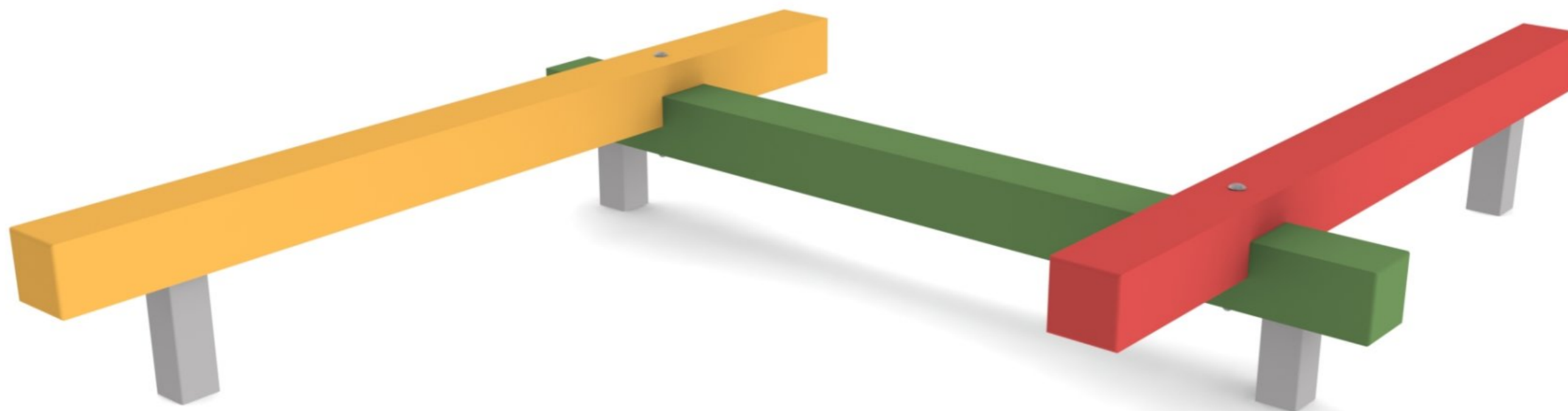
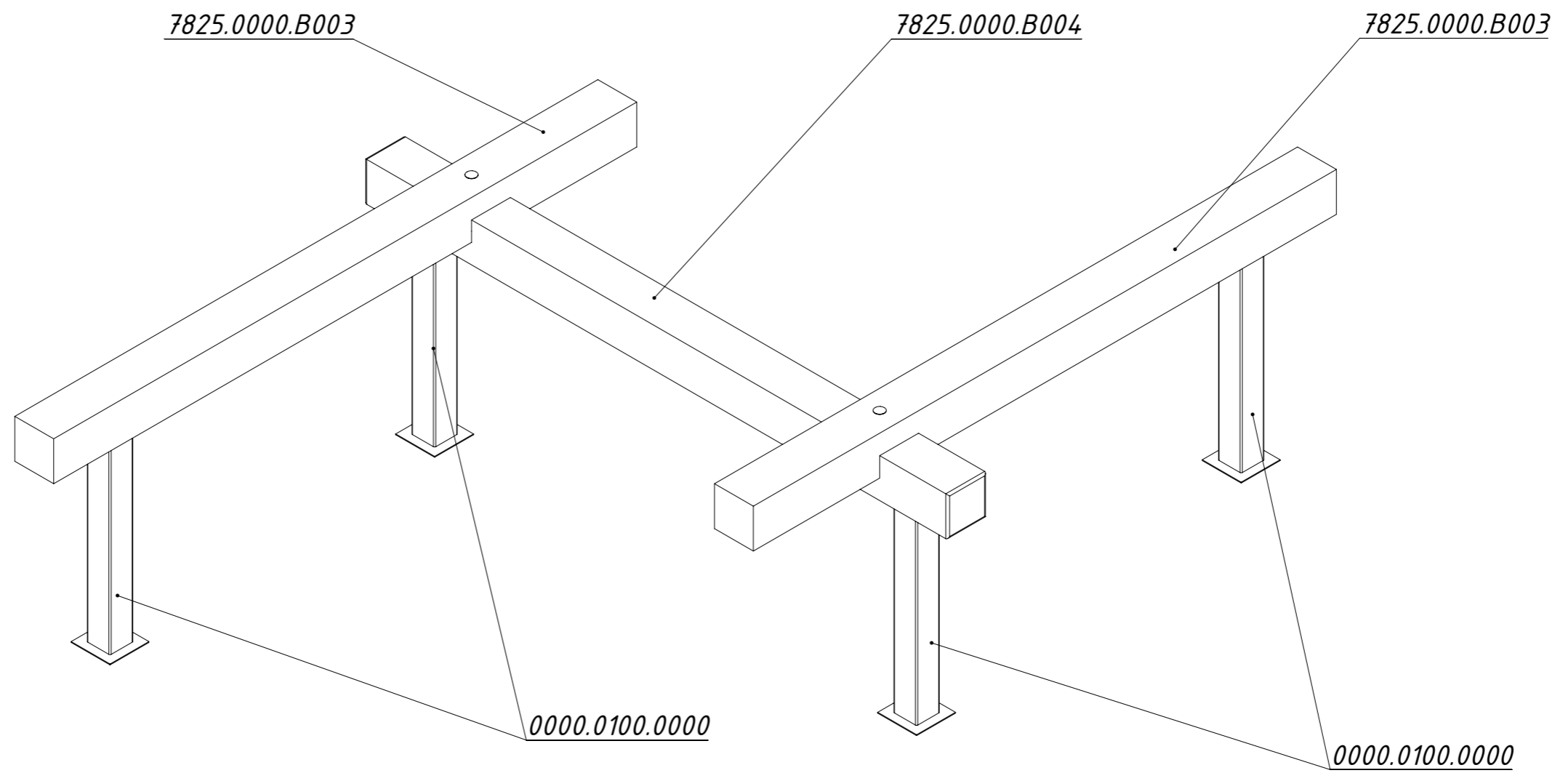
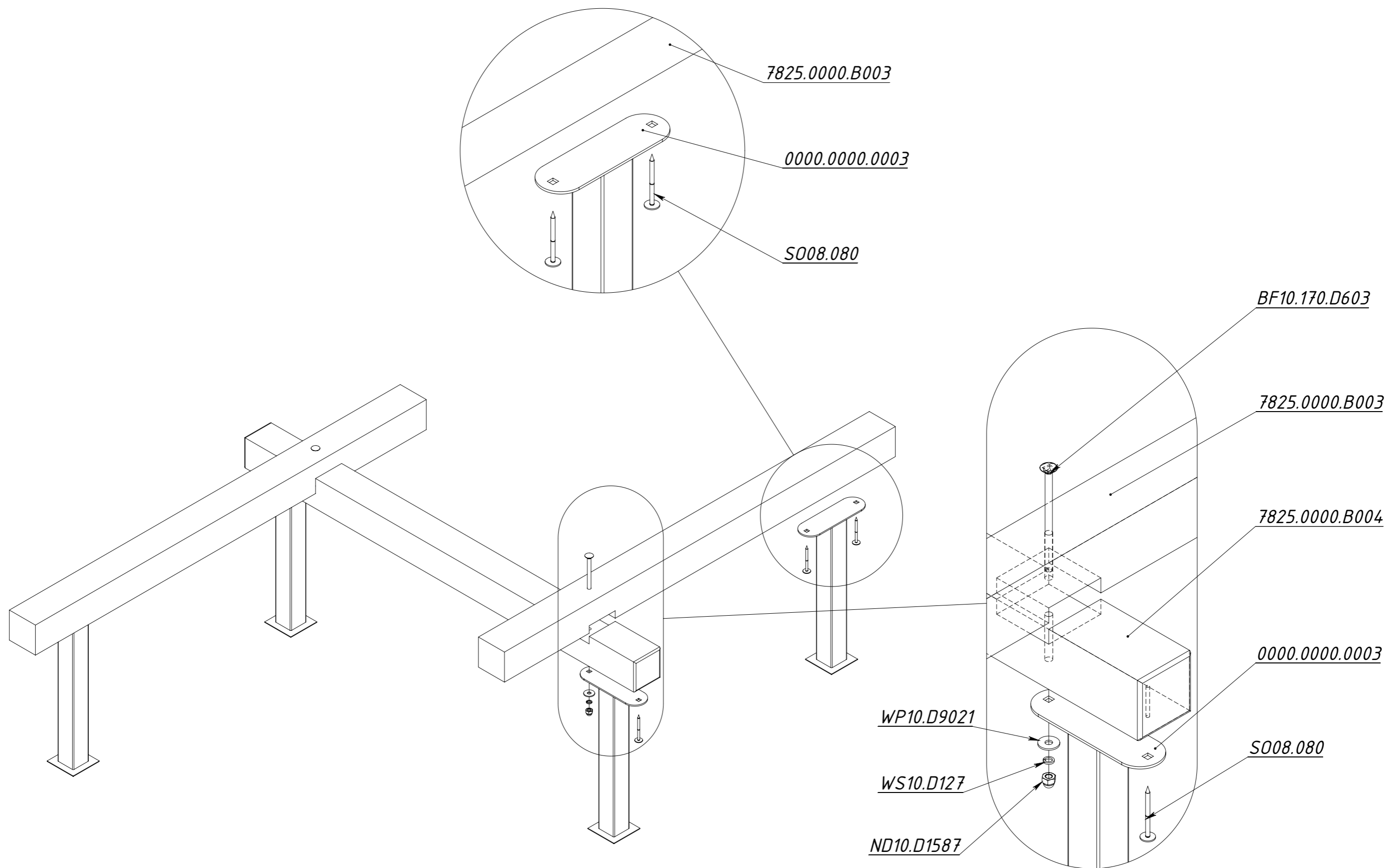

Рисунок 2